

M60EN019

1/2

Surinkimo schema
Схема сборки
Assembling scheme

Reikalingi įrankiai:

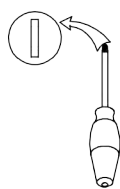

Инструменты для сборки:

Requiring tools:

x1

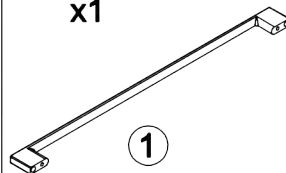

x2



x8

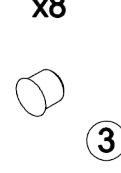

3

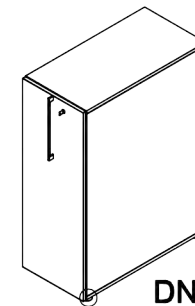

DNE314

1

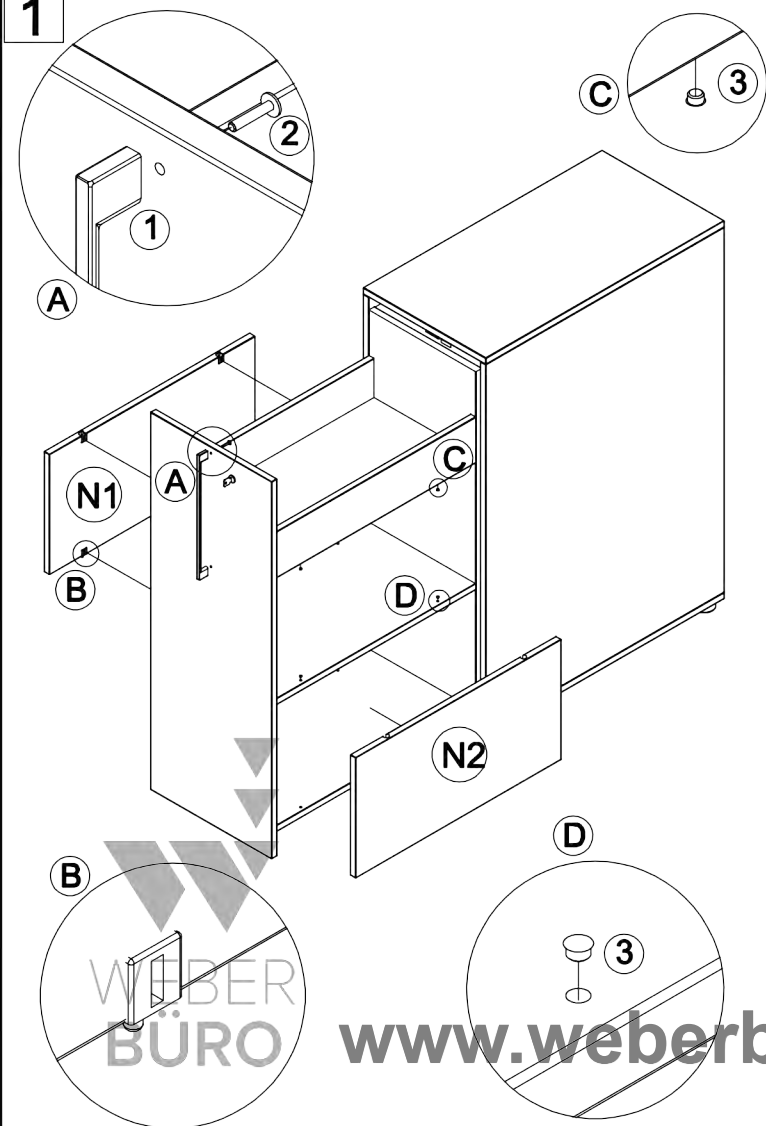

2

Nugarėlių tvirtinimo variantą derinti su užsakovu.

Вариант стенок нужно наладить с заказчиком

The positions of cabinet's back panels should be discussed with the customer.

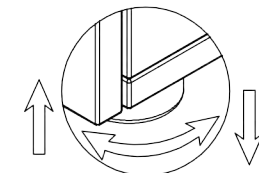

2.1

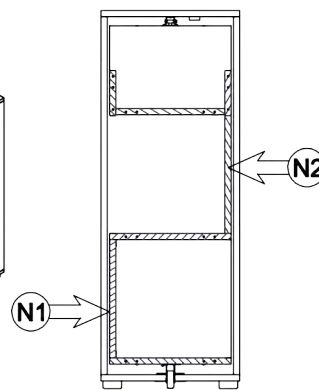
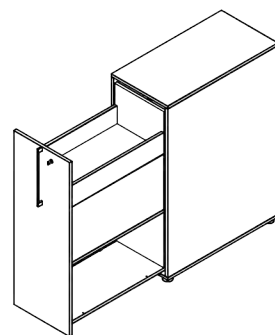

2.2

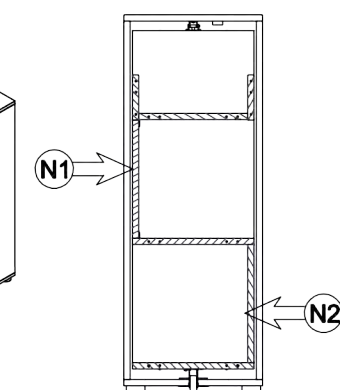
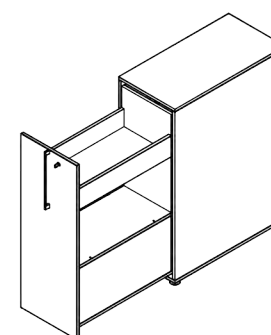

2.3

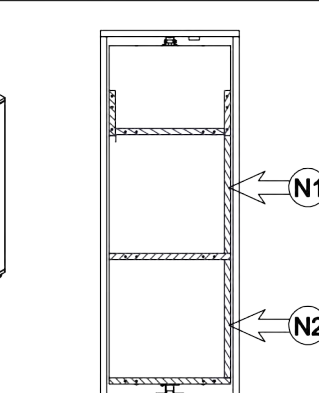
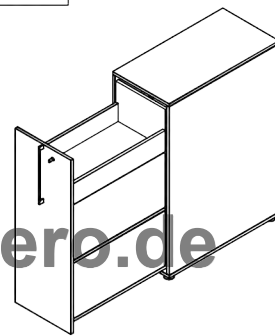

2.4

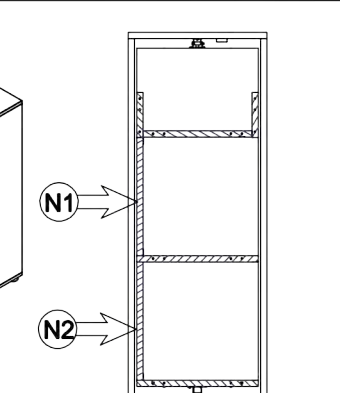
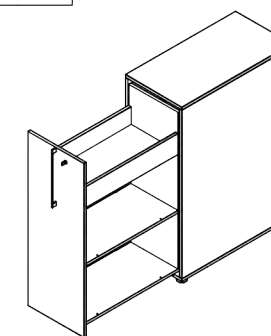

www.weberbuero.de

ASSEMBLING

1

SPRING INSTALLATION INSIDE THE SHELF

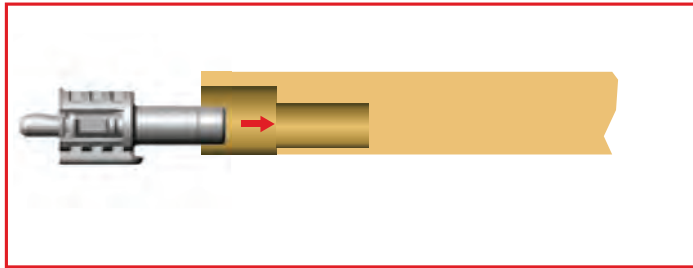

2

INSERT THE SHELF DIAGONALLY INTO THE CABINET (ALSO WITH DOOR ALREADY ASSEMBLED)

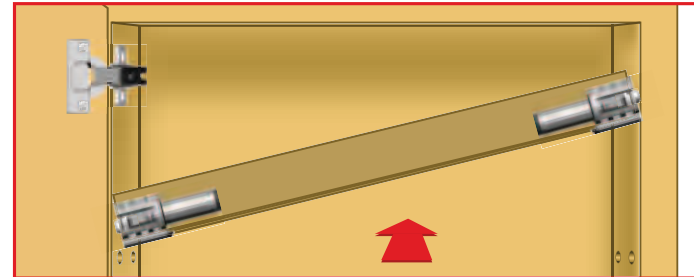

3

PLACE ONE SIDE OF THE SHELF IN THE REQUIRED POSITION UNTIL THE SPRING PINS FIT INTO THE CORRESPONDING HOLES.

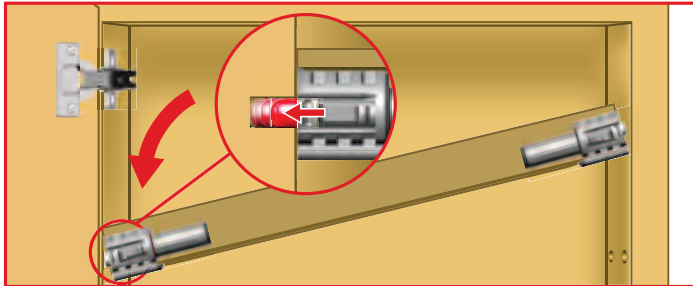

4

LEVEL THE OPPOSITE SIDE UNTIL THE SPRING PINS FIT INTO THE CORRESPONDING HOLES

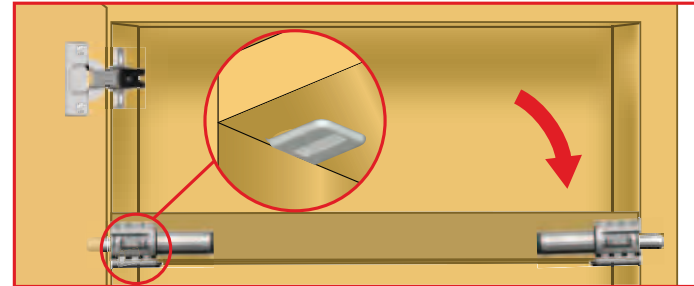

SHELF REMOVAL AND REPOSITIONING

SHELF REMOVAL

INSERT THE SCREWDRIVER BLADE INTO THE ZINC ALLOY SOCKET AND PULL IT BACKWARDS UNTIL THE PIN RETREATS AND IS FINALLY LOCKED (JUST ON ONE SIDE OF THE SHELF). LOWER THE SIDE AND EASE THE SHELF DIAGONALLY OUT.

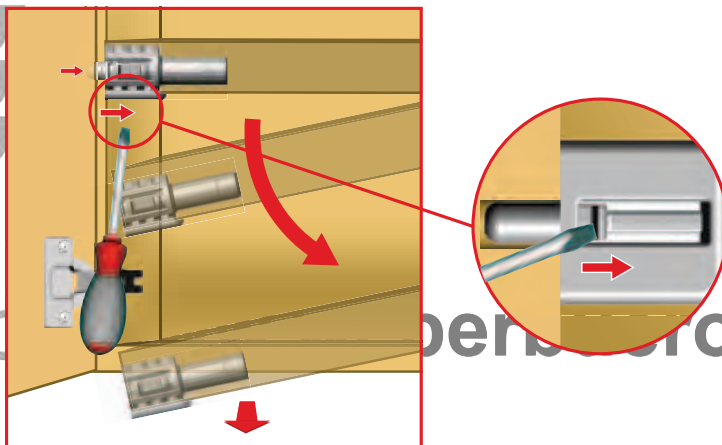

SHELF REPOSITIONING

INSERT THE SCREWDRIVER BLADE BETWEEN THE PLASTIC EDGE AND THE ZINC ALLOY SOCKET. PRESS IT OUTWARDS UNTIL THE PIN IS RELEASED. TO REPOSITION THE SHELF REPEAT OPERATIONS AS SHOWN IN PCS. 2-3-4.

