

<b>M60EC004</b>	
EN	Assembling scheme
DE	Aufbauanleitung
FR	Schéma d'assemblage

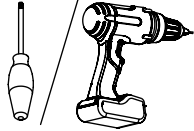

00 : 10

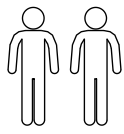
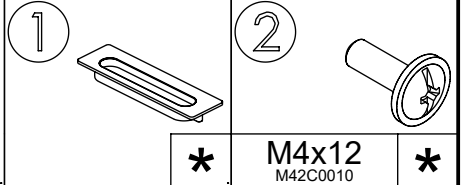

EN	Variety of the sizes
DE	Vielzahl der Größen
FR	Variété des tailles

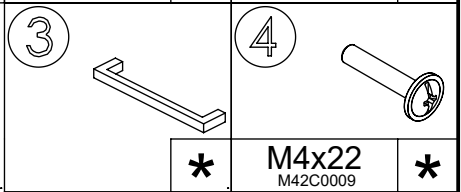
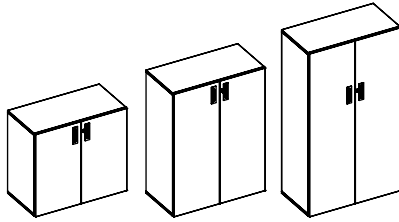

EN	Type of the door
DE	Art der Tür
FR	Type de porte

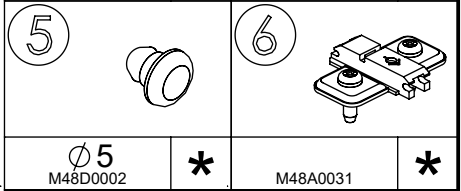
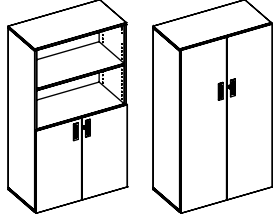

EN	Type of the door handle
DE	Art des Türgriffs
FR	Type de poignée de porte

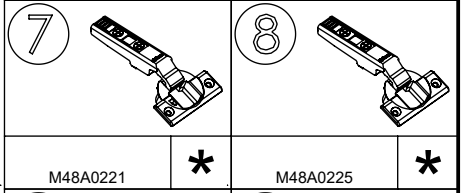
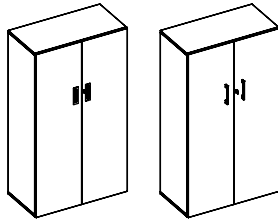

EN	With or without the lock
DE	Mit oder ohne Schloss
FR	Avec ou sans la serrure

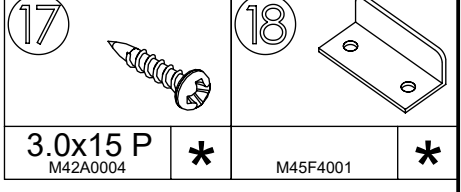
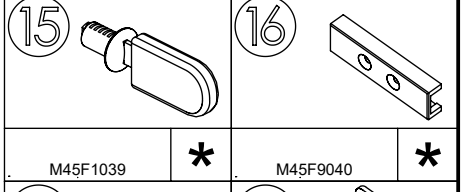
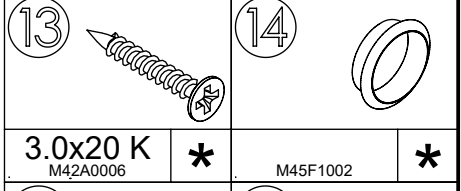
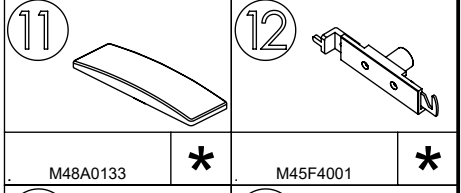
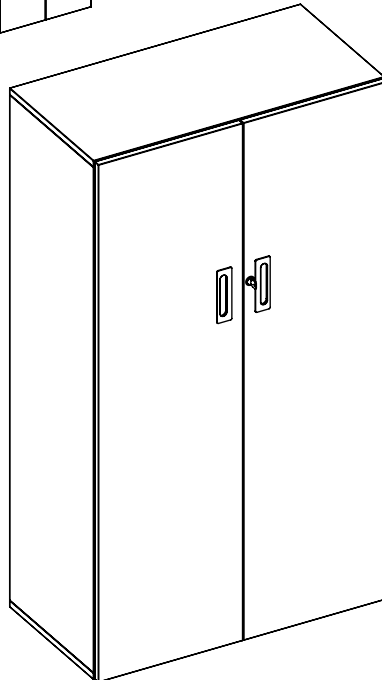
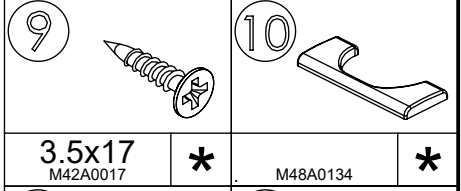
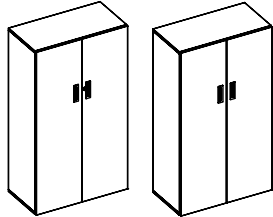

EN	*Quantity depends on the type of the cabinet.
DE	*Menge hängt von der Art des Schrankes ab.
FR	*La quantité dépend du type d'armoire.

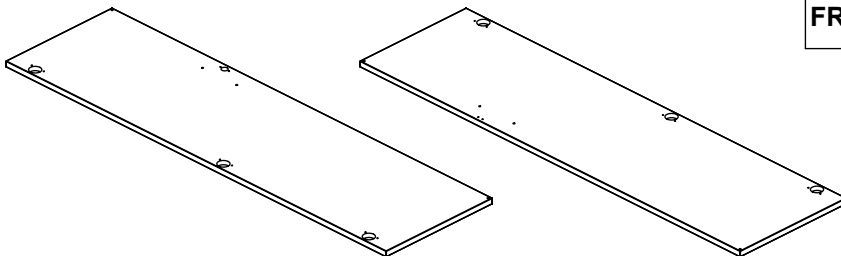
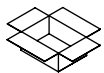

a - x1

b - x1

1A

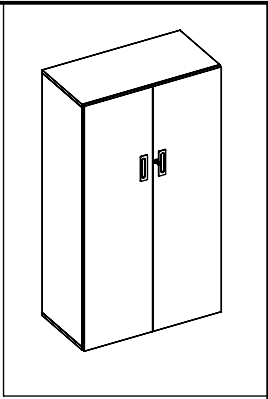
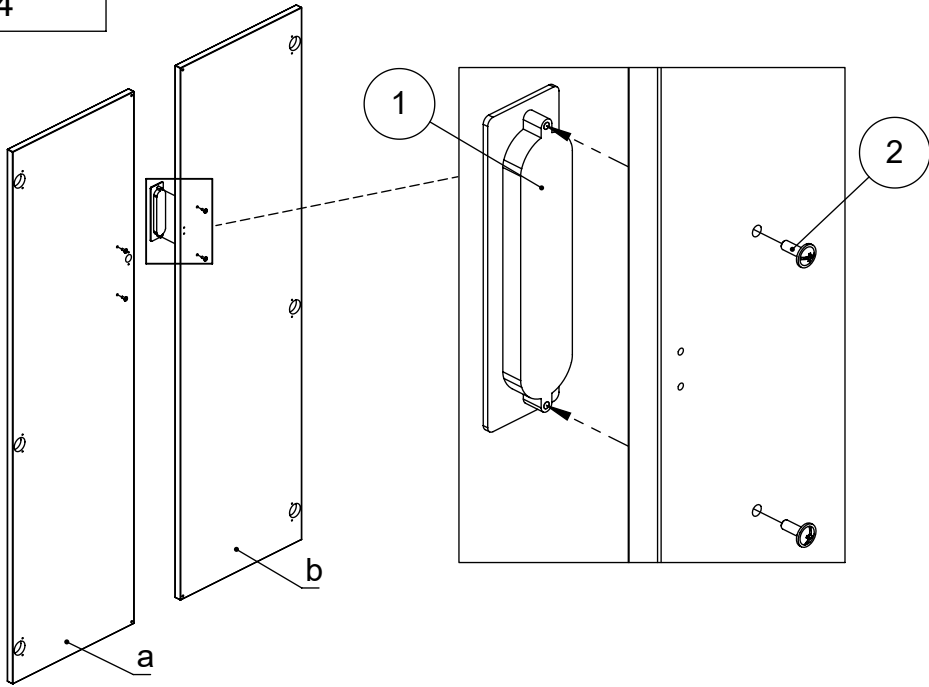

1B

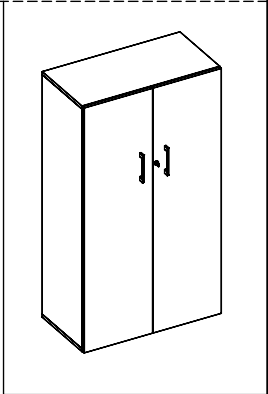
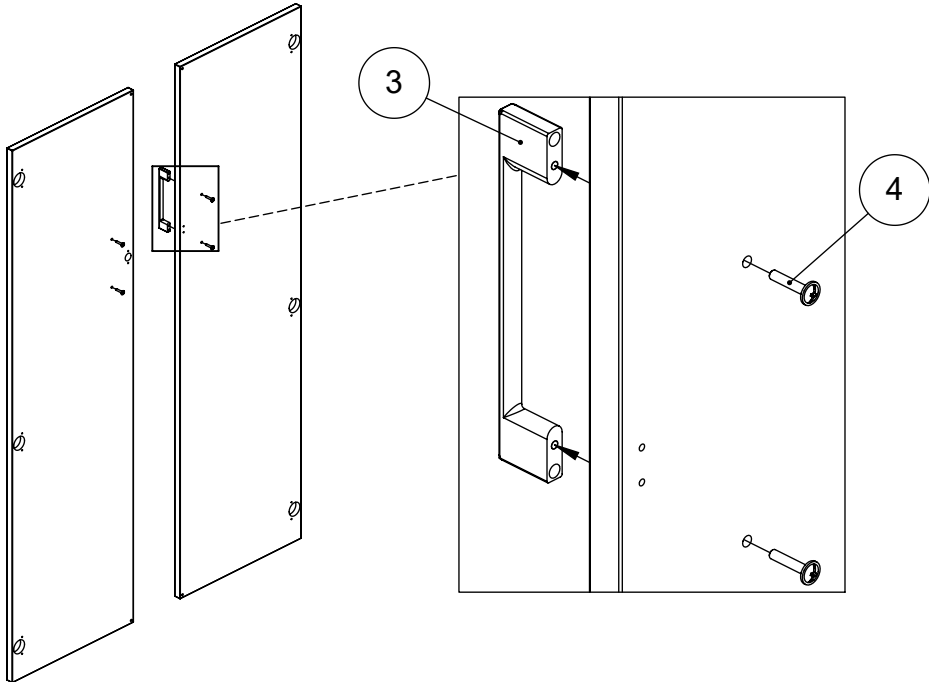

2

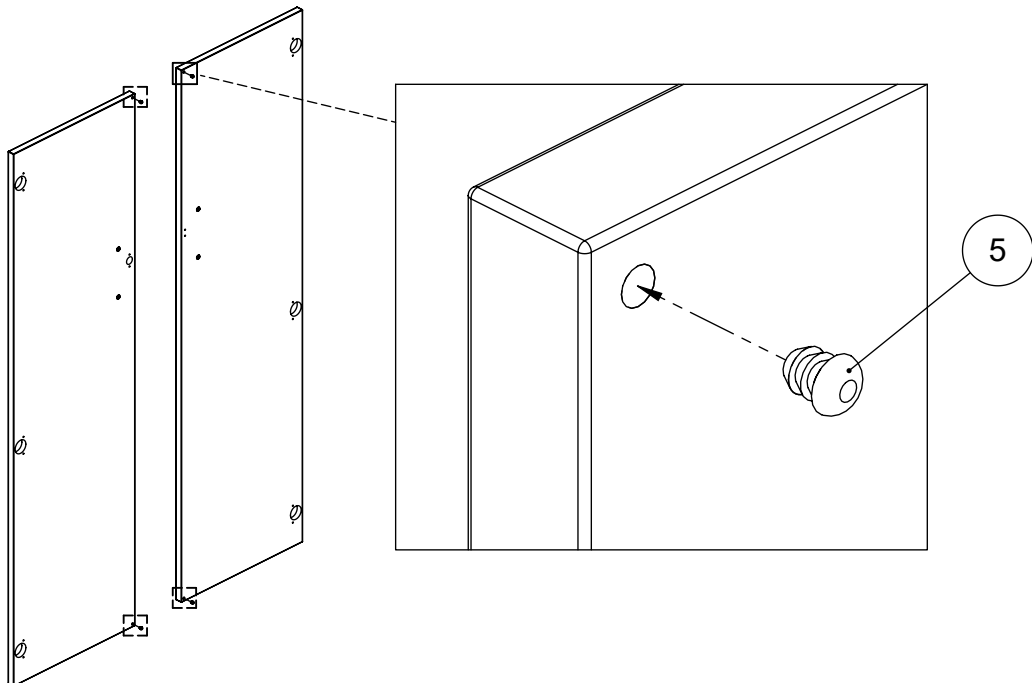

3

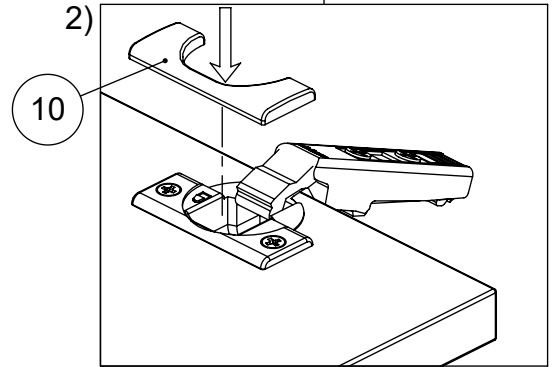
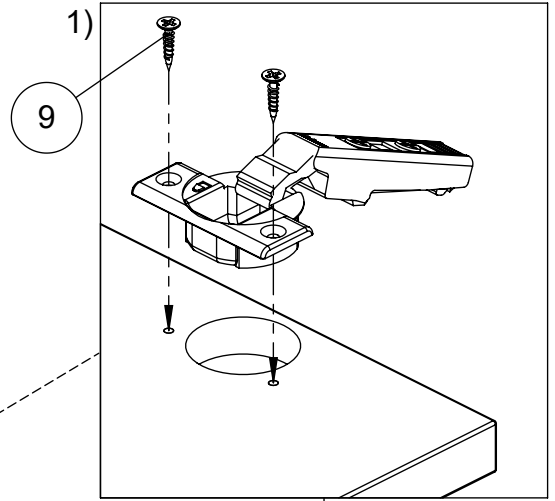
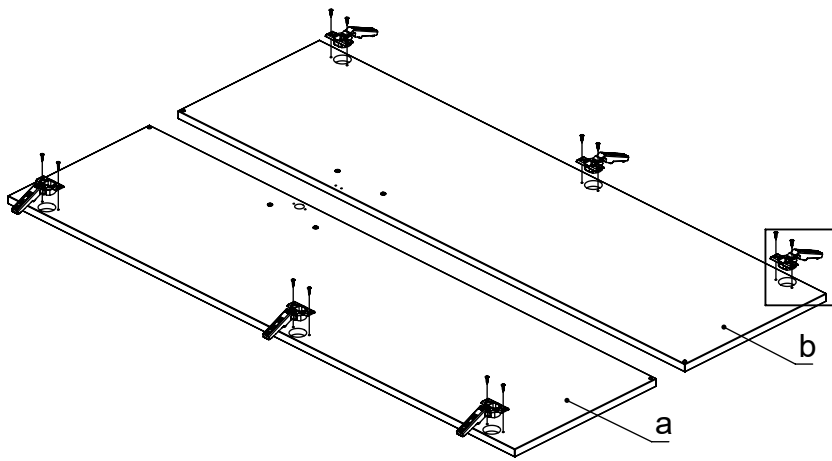

EN \*Soft close hinges

DE \*Dämpfung Scharniere

FR \*Charnières à fermeture douce

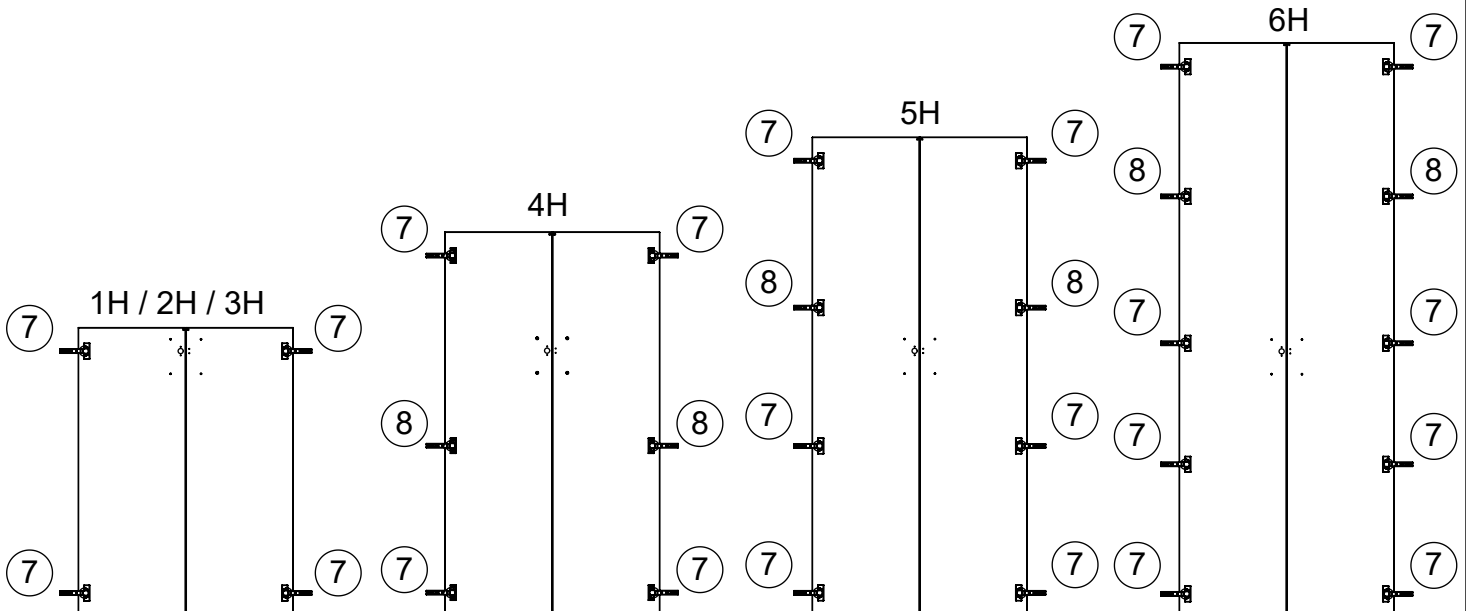
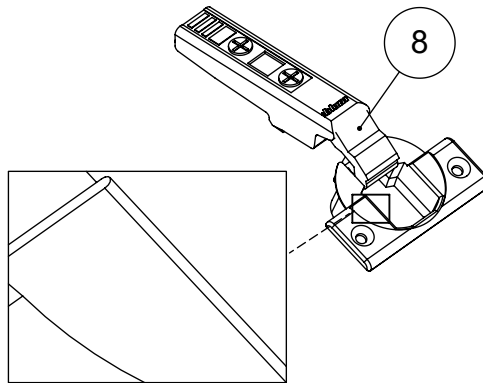
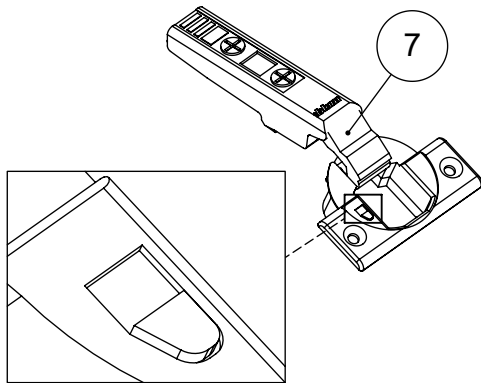

4

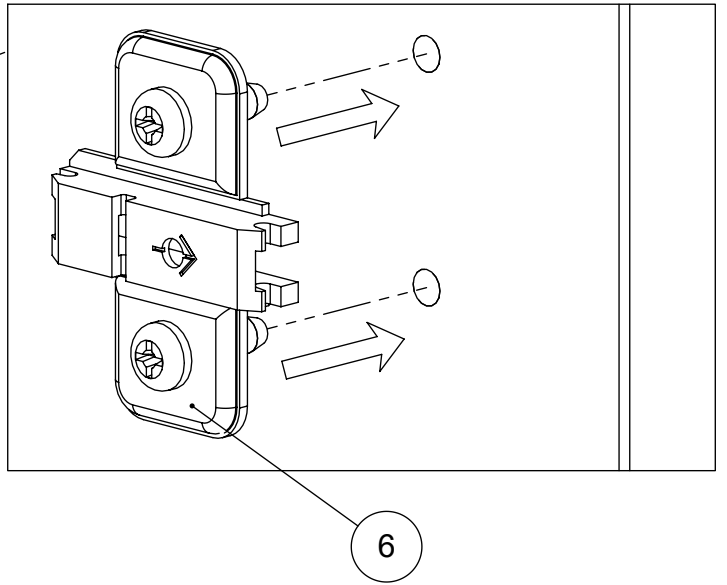
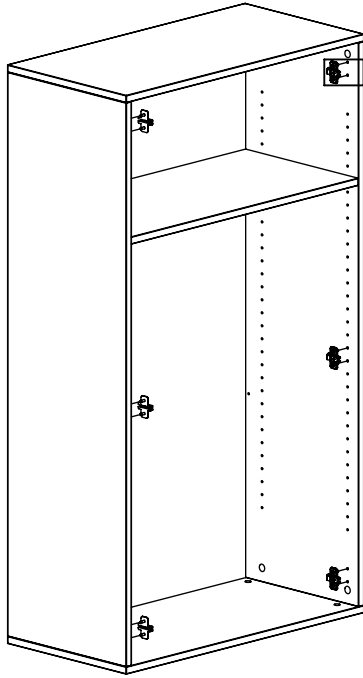

5

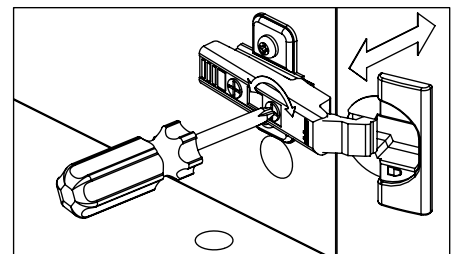
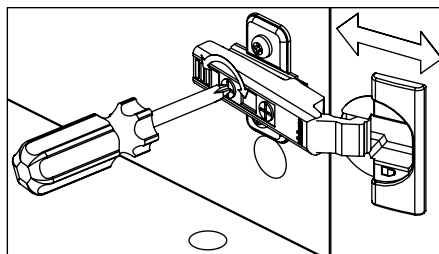
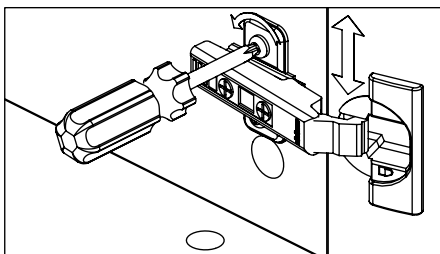
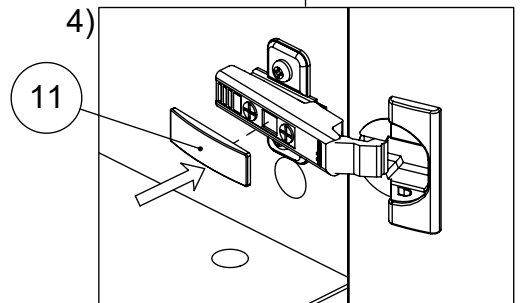
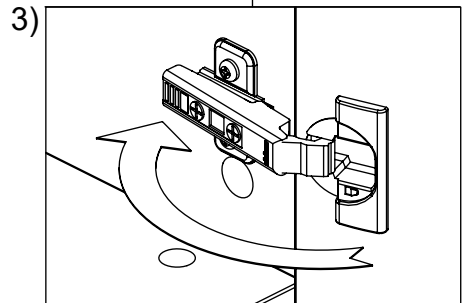
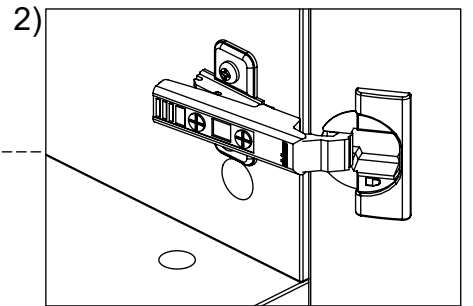
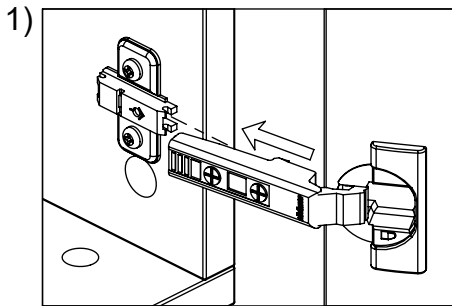
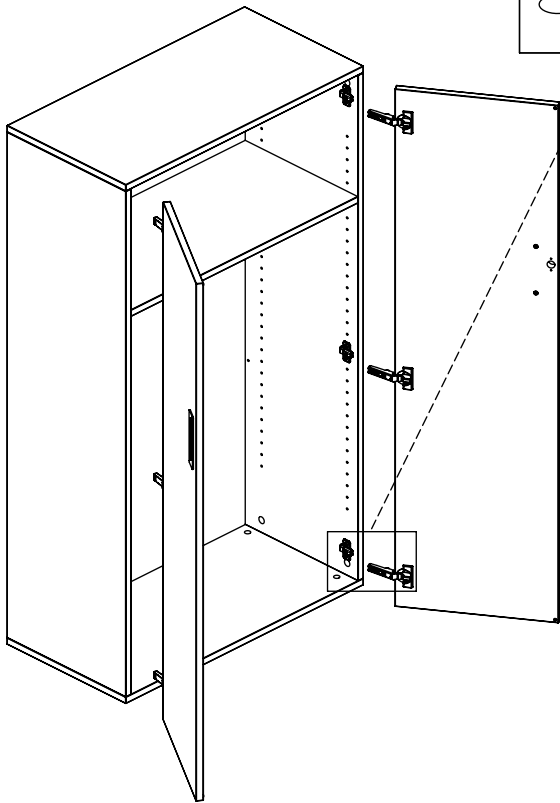

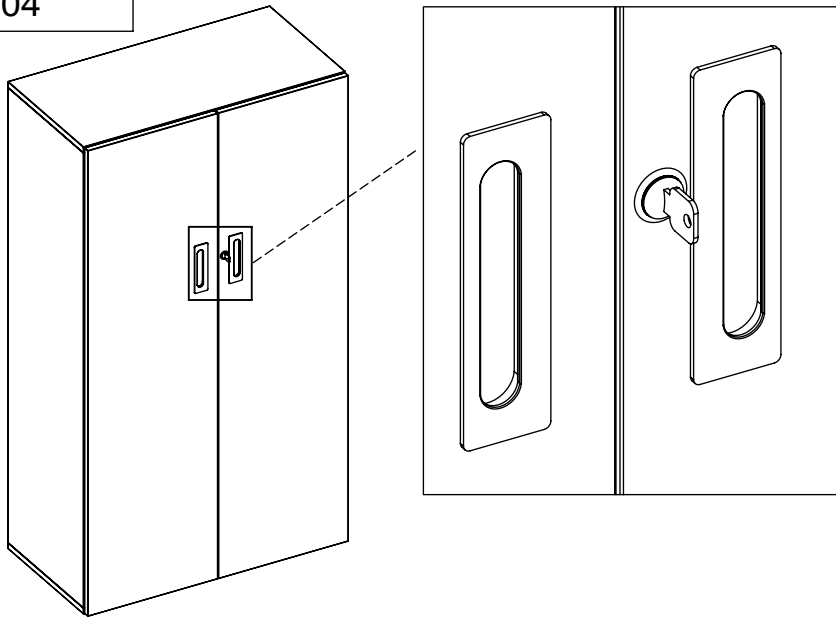

1

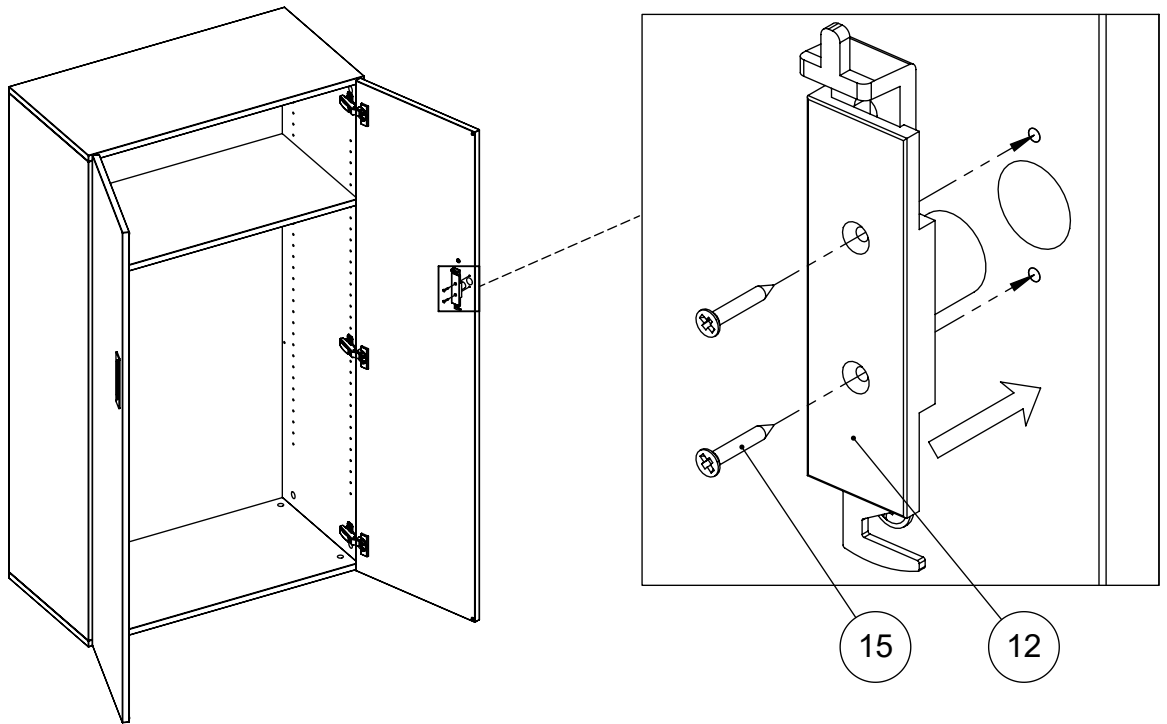

2

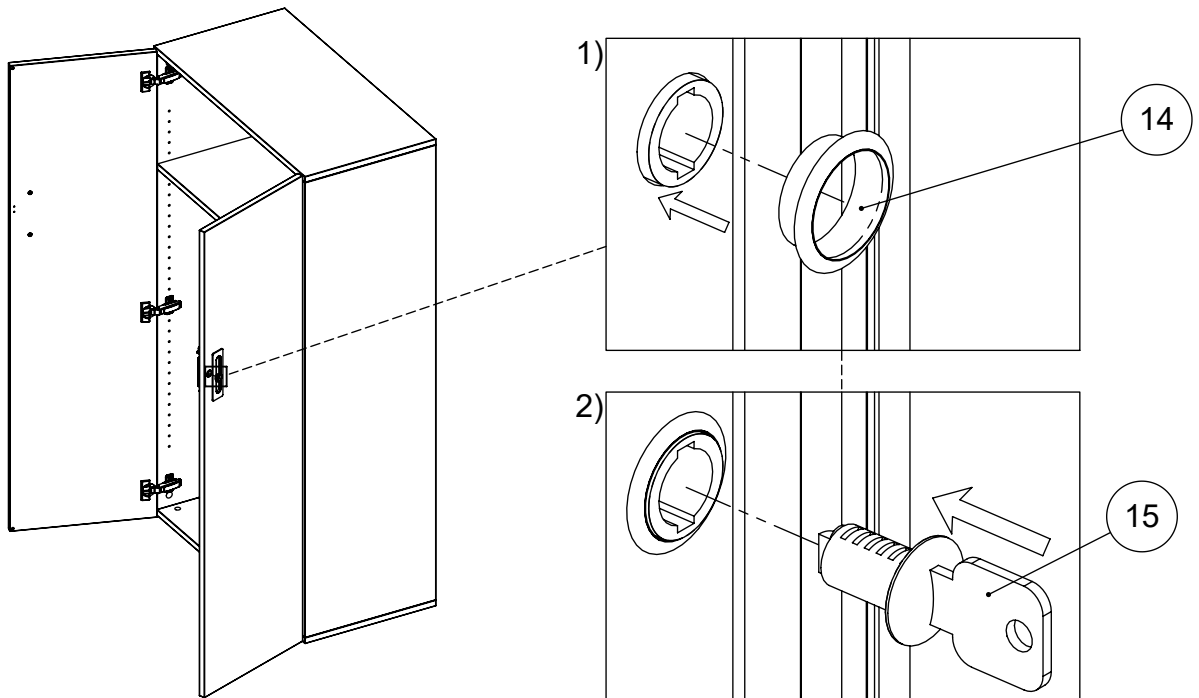

3

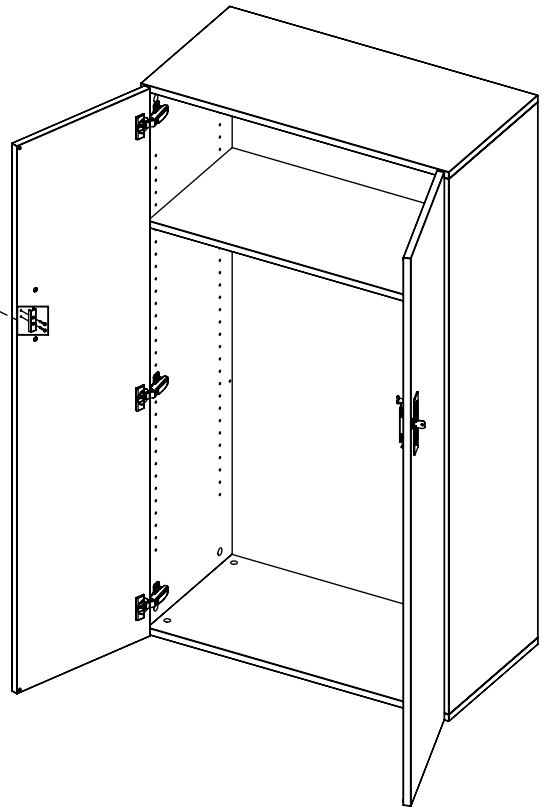
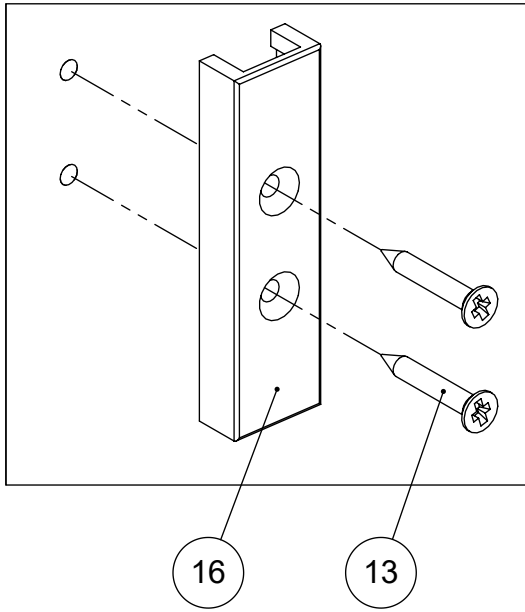

4

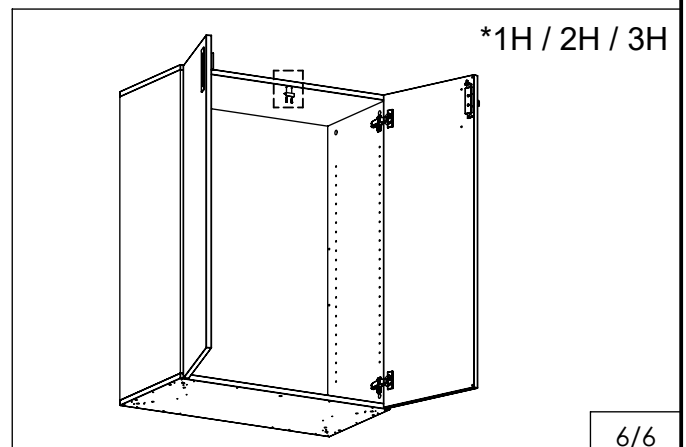
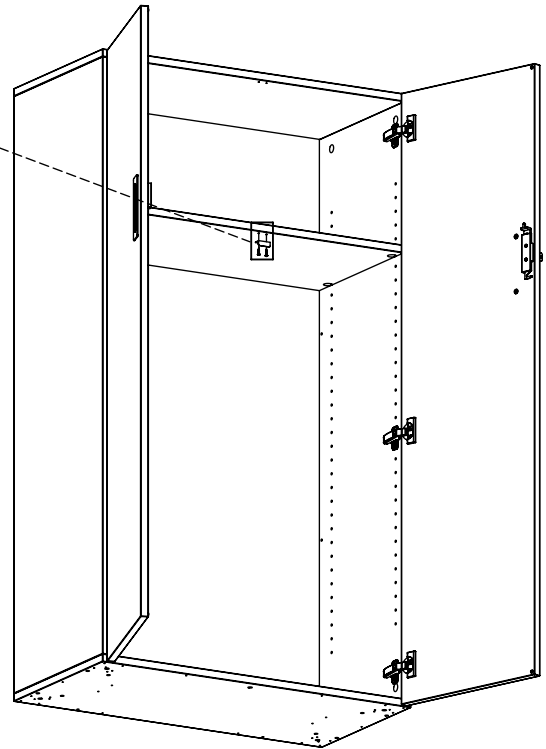
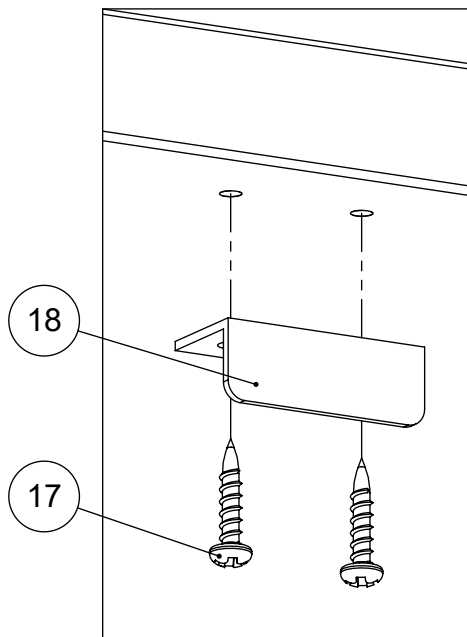

<b>M60EC103</b>			①		②		③		
EN	Assembling scheme		15/18 M42B0001	x8	5/11x34 M42B0022	x8	∅8x30 M42H0001	x8	
DE	Montageschema								
FR	Schéma d'assemblage								
<p>a - x1</p>		<p>b - x1 c - x2 d - x1</p>		④		⑤		⑥	
				∅4/18 M45A3013	x8	∅10/13 M45A2029	x4	4.5x45 M42A0110	x2
				⑦		⑧		⑨	
				4,0x15 M42A0056	*	6,3x13 M42C0029	*	20x17 M42J0027	*

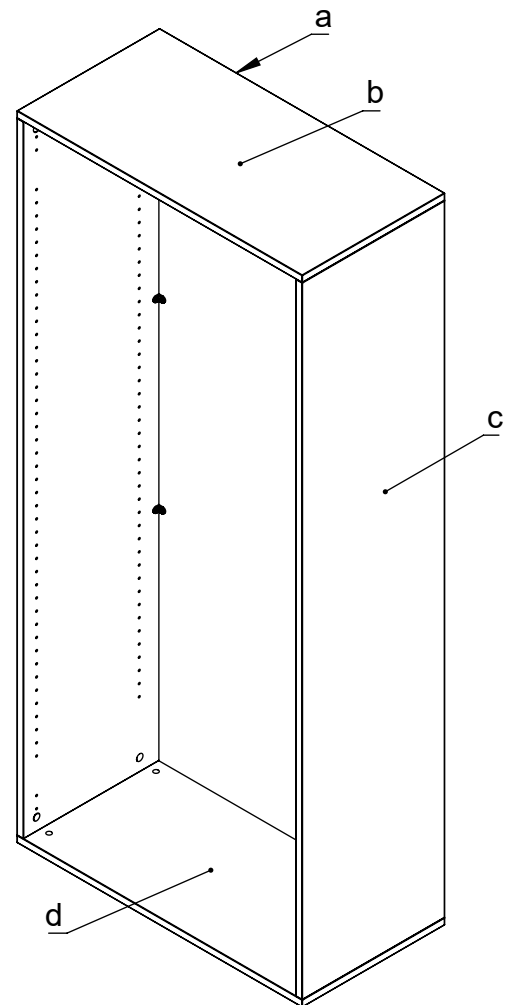
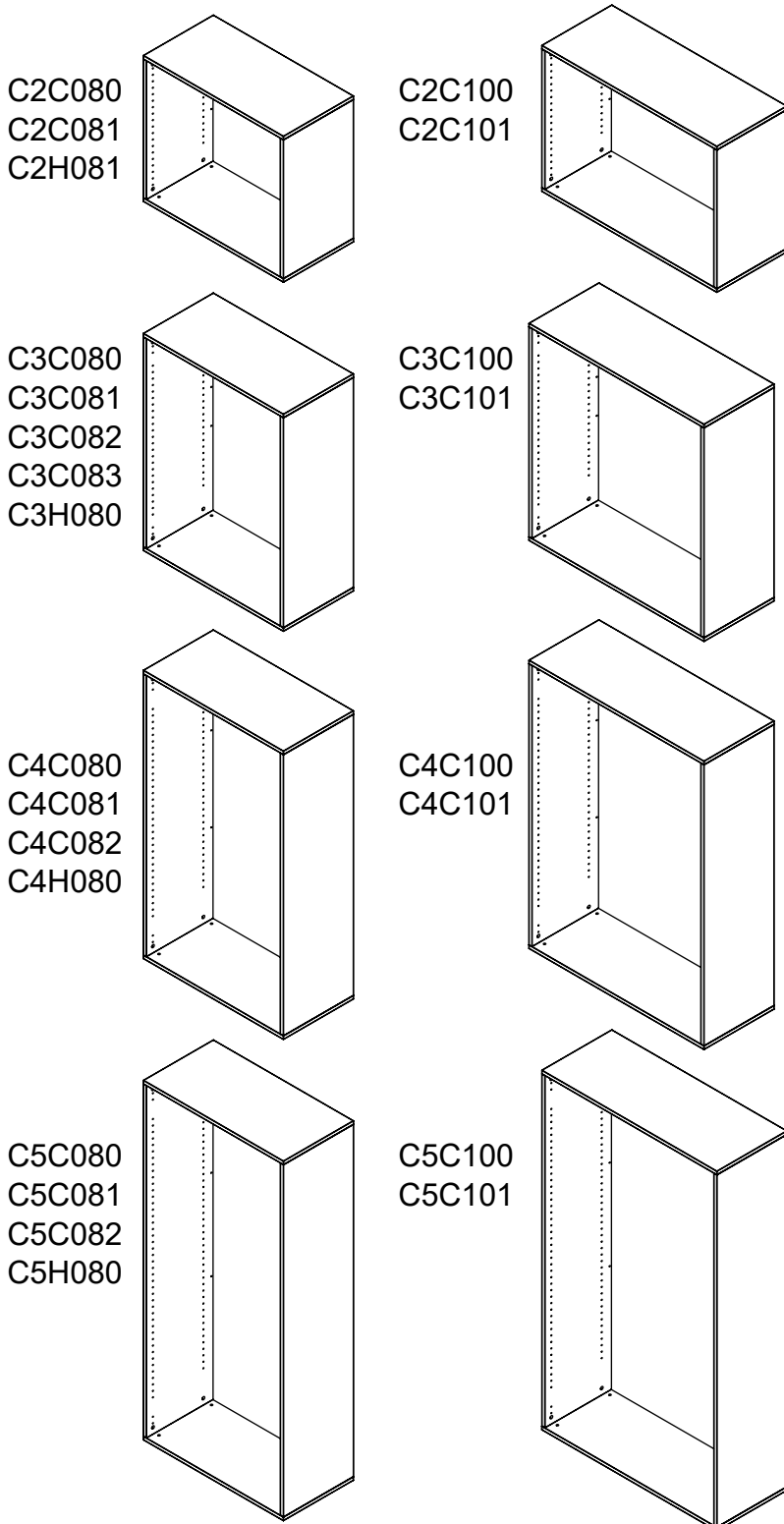

EN	*Configuration depends on order option
DE	*Die Konfiguration hängt davon der Bestelloption ab
FR	*La configuration dépend de l'option de commande

1

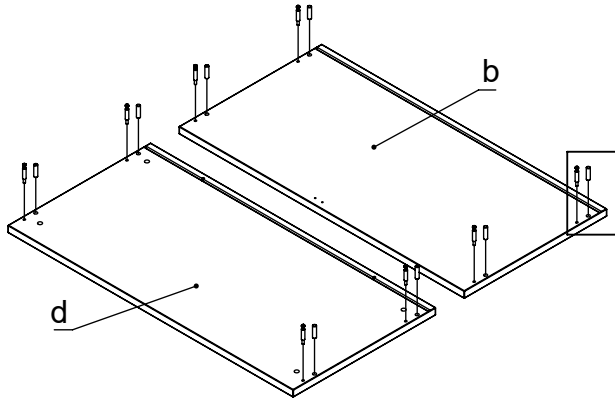

2

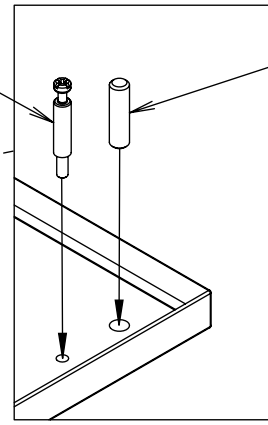

3

2

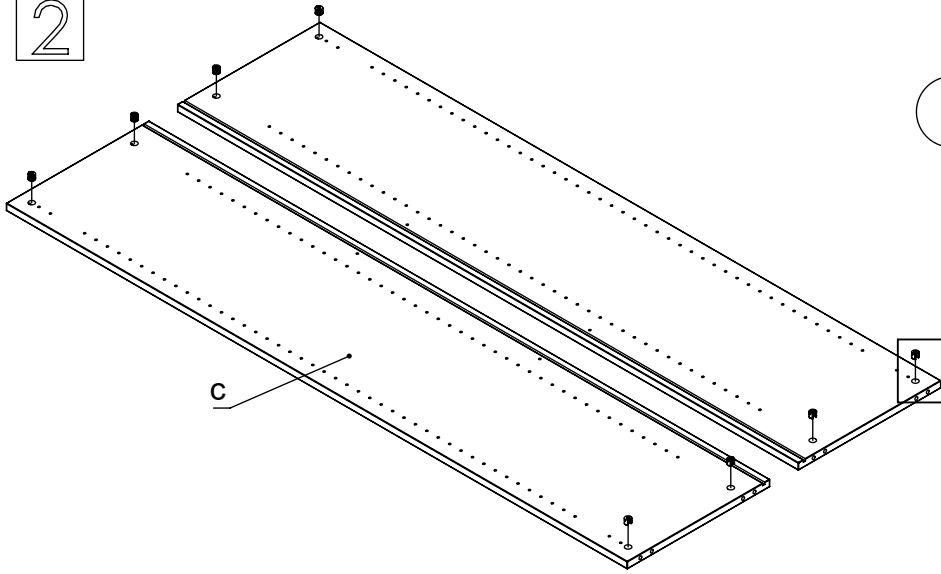

1

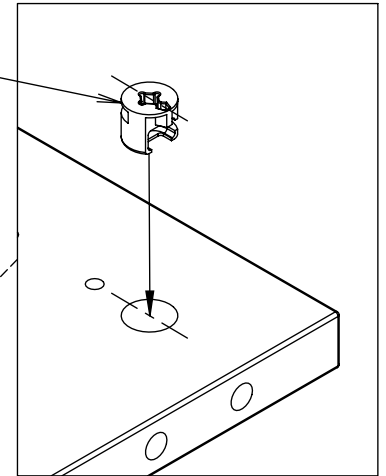

3

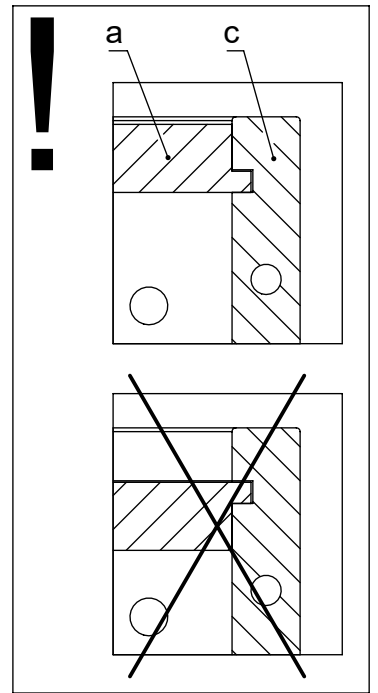
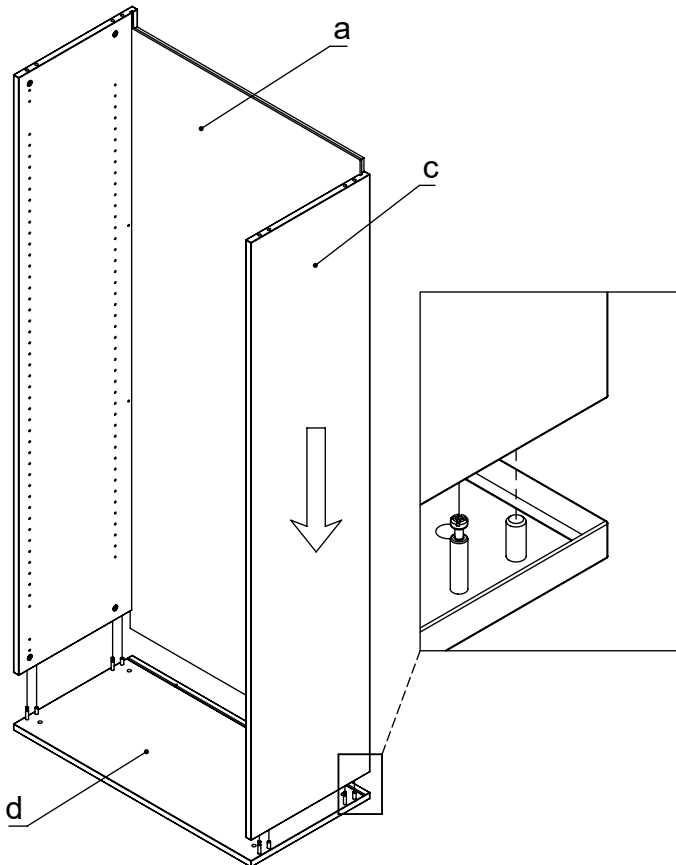



4

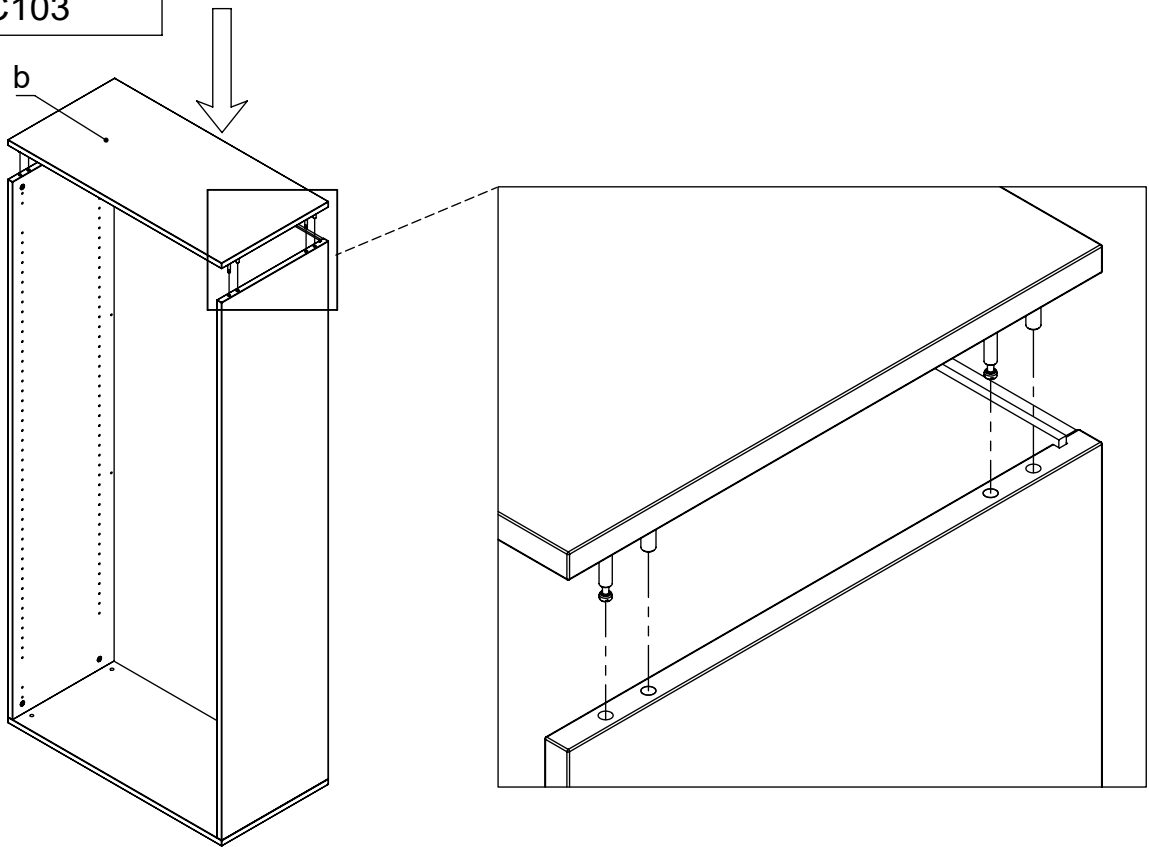

5

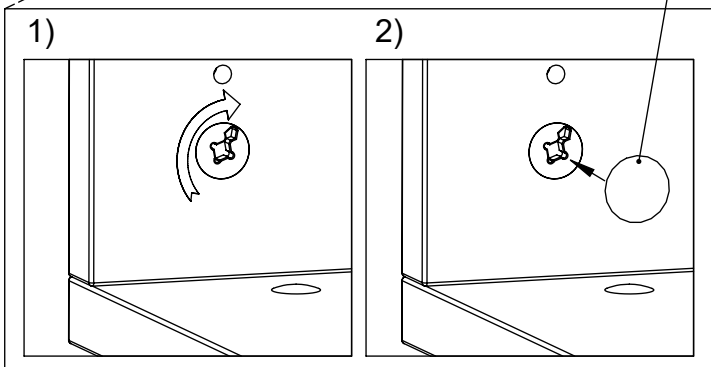
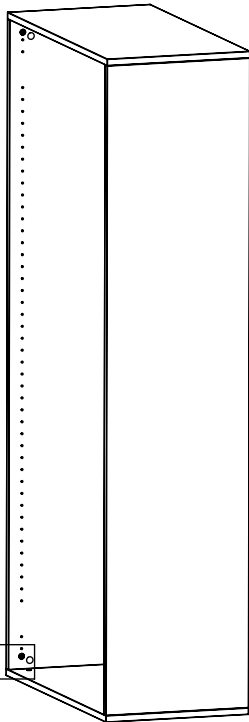

6

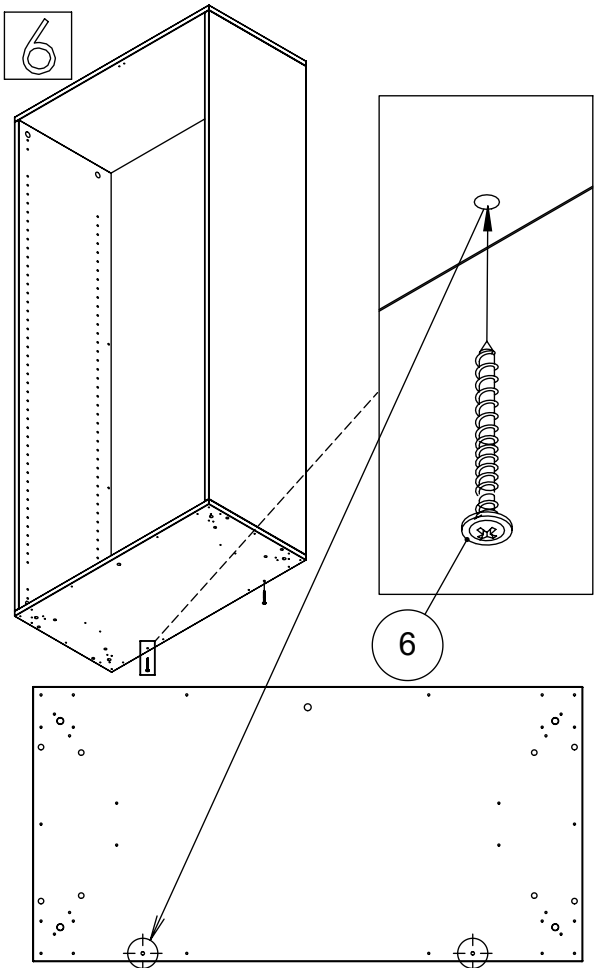

**EN** Important! Use fasteners to ensure stability.  
**DE** Achtung! Verwenden Sie Befestigungselemente, um die Stabilität zu gewährleisten.  
**FR** Importante! Utilisez des attaches pour assurer la stabilité.

7

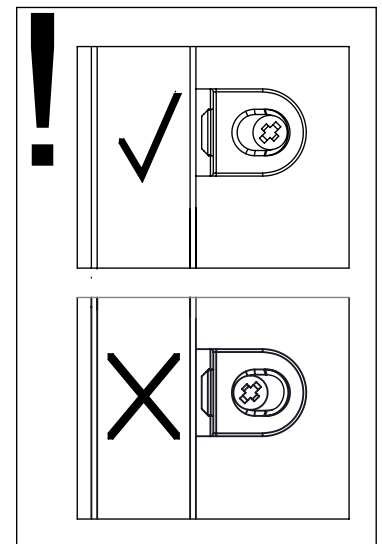
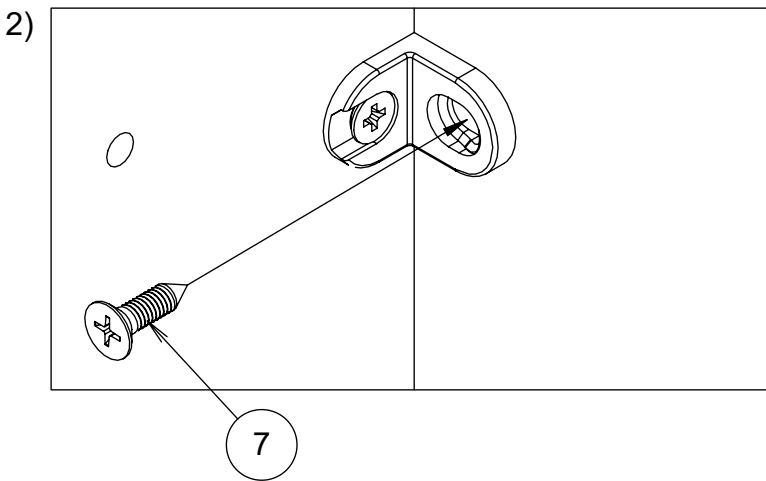
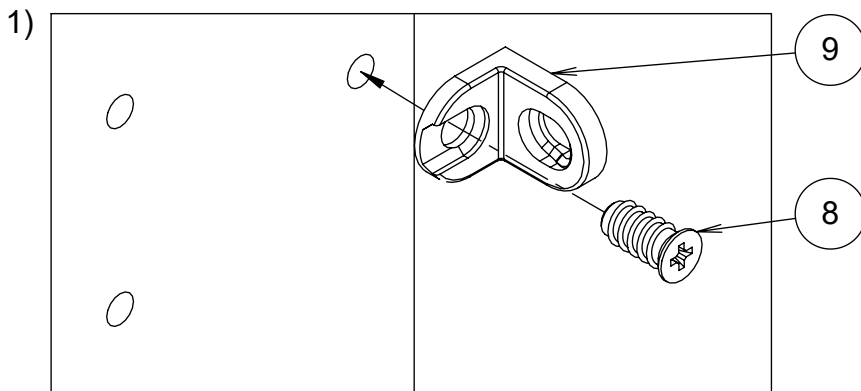
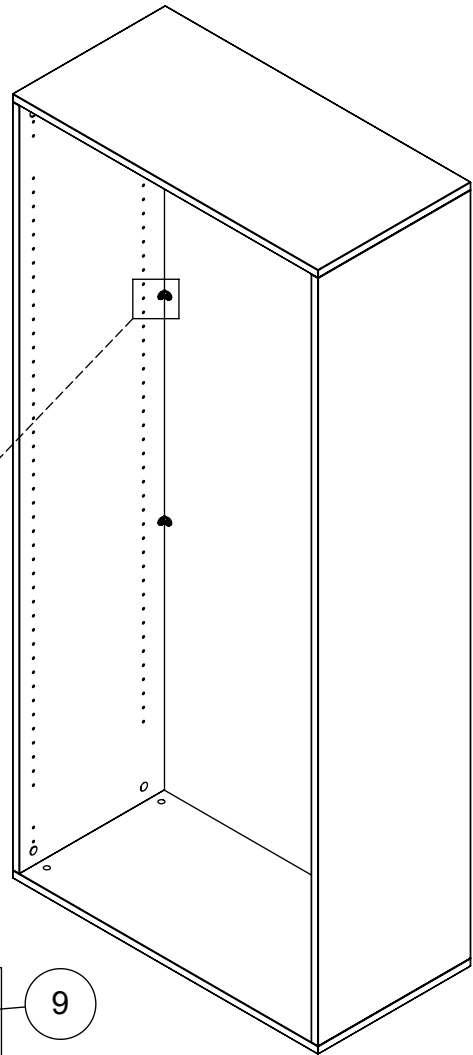

<b>EN</b>	Important! Use fasteners to ensure stability.
<b>DE</b>	Achtung! Verwenden Sie Befestigungselemente, um die Stabilität zu gewährleisten.
<b>FR</b>	Importante! Utilisez des attaches pour assurer la stabilité.

# M60EC108

EN Assembling scheme  
 DE Aufbauanleitung  
 FR Schéma d'assemblage

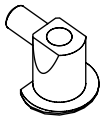
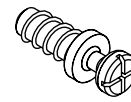
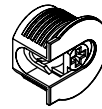
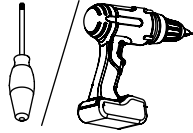

∅ 20x12.5  
M42B0049



∅ 5x11  
M42B0067



M42O0006



**A** EN Fixed shelves  
 DE Festen Einlegeböden  
 FR Tablettes fixes

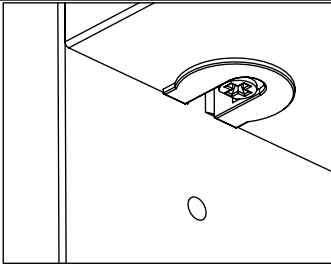

**B** EN Removable shelves  
 DE Abnehmbare Einlegeböden  
 FR Étagères amovibles

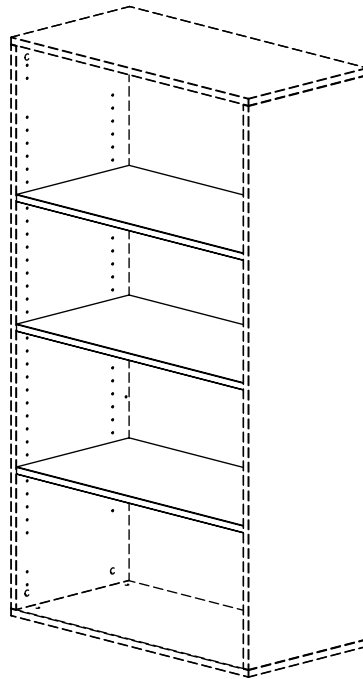
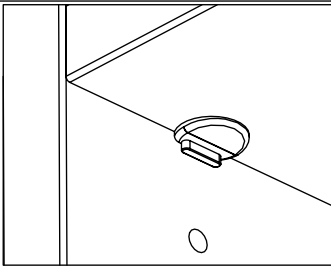

a - x\*

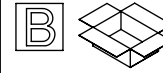

b - x\*

EN Depends on order option

DE Hängt von der Bestelloption ab

FR Dépend de l'option de commande

**A** EN Note position of the fixed shelves  
 DE Position der festen Regale notieren  
 FR Notez la position des étagères fixes

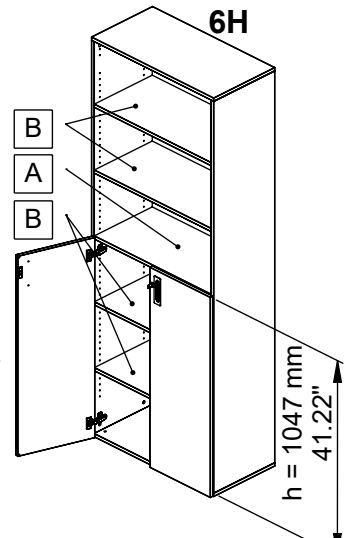
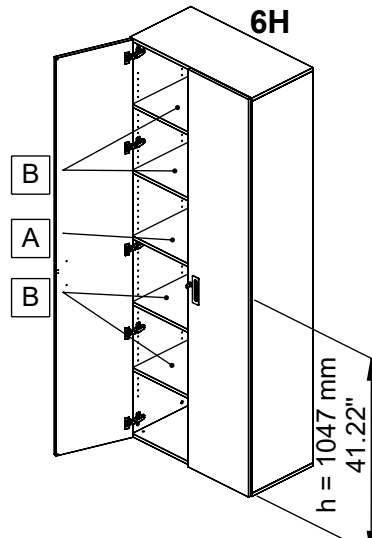
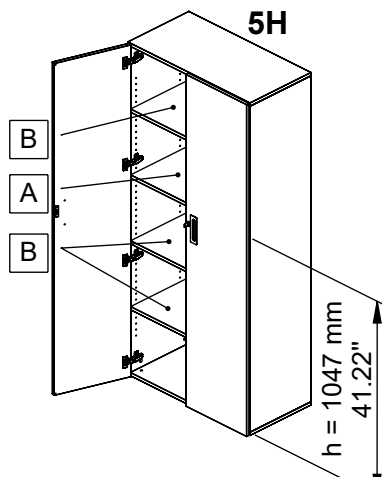
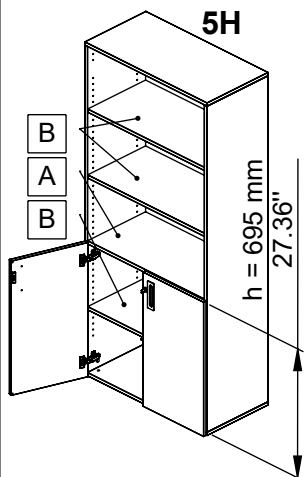
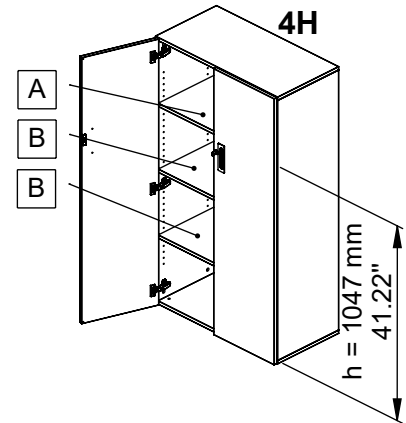
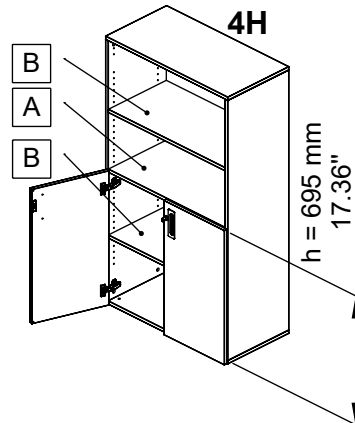
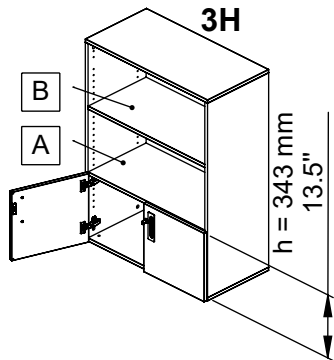
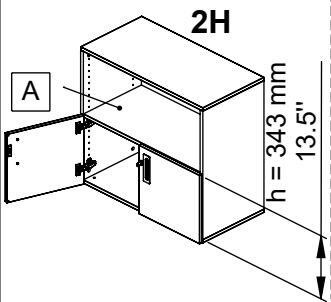
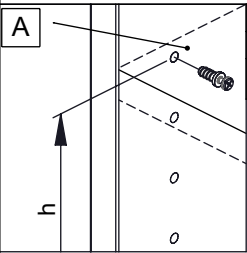

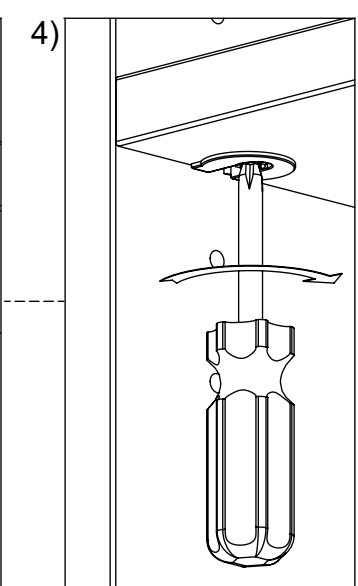
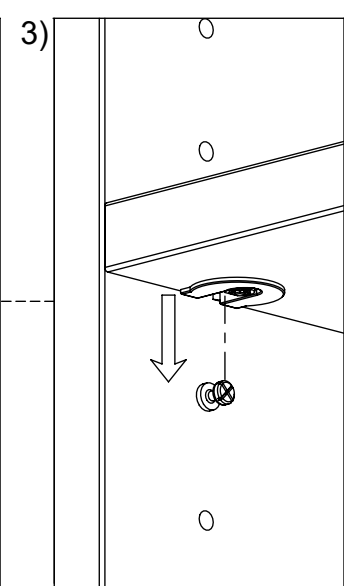
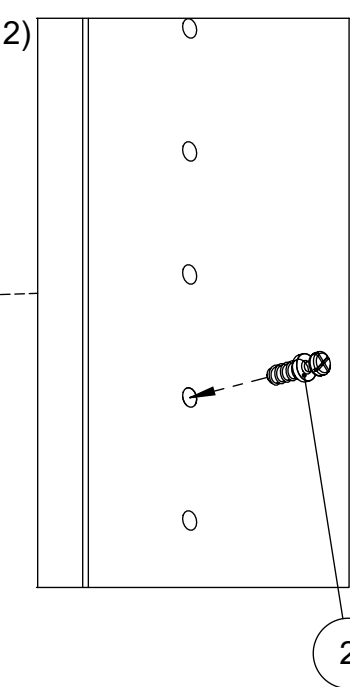
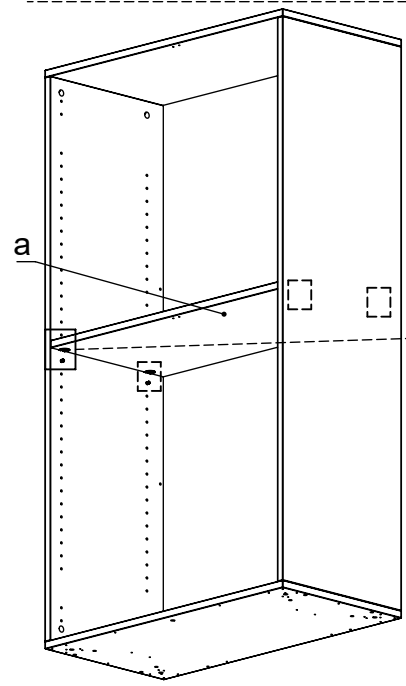
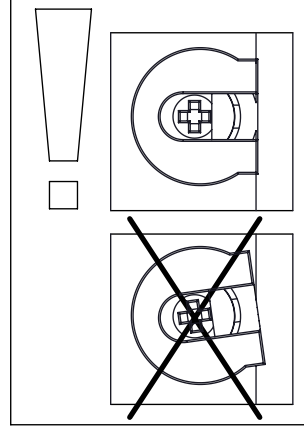
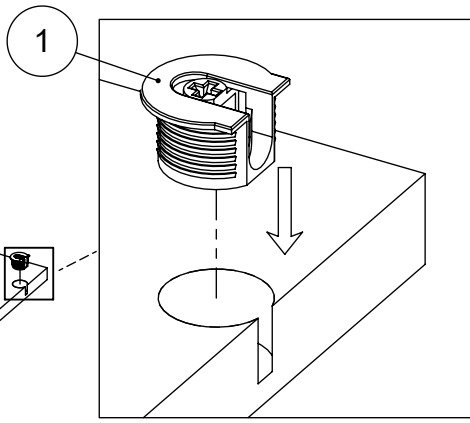
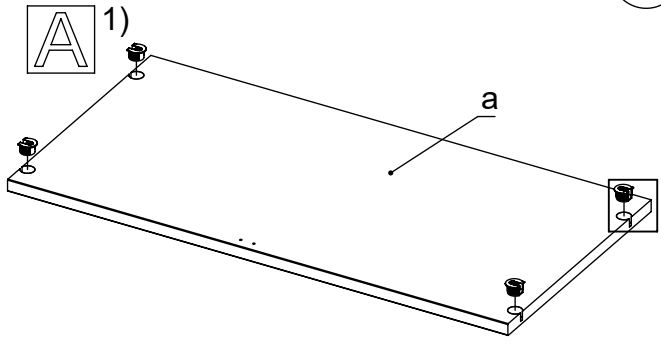

B

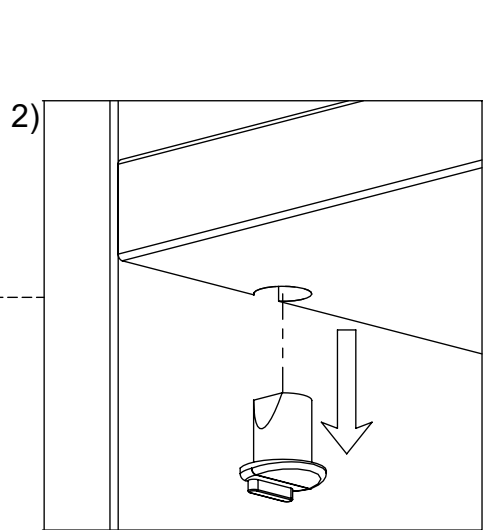
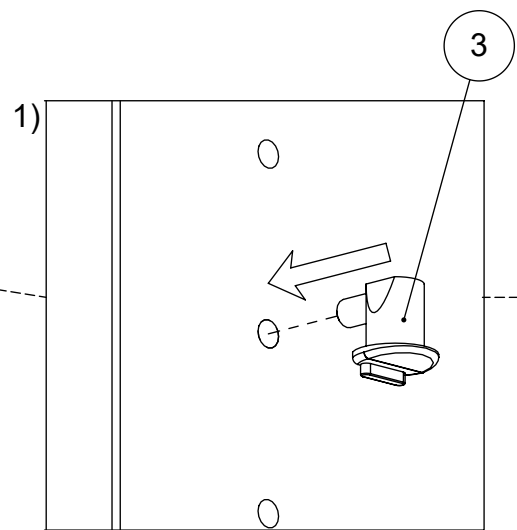
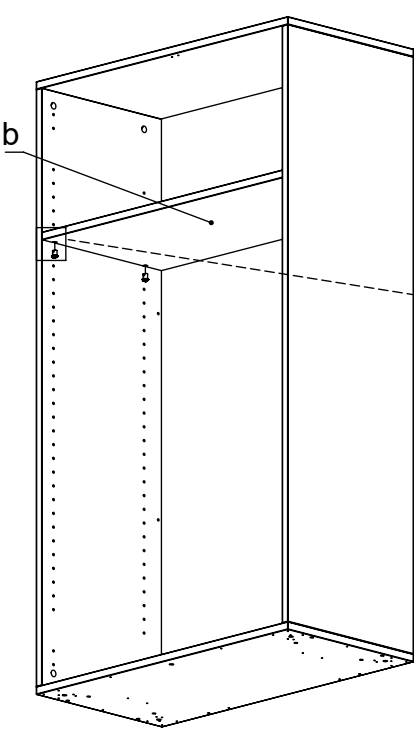

# M60EC115

EN Assembling scheme  
DE Aufbauanleitung  
FR Schéma d'assemblage

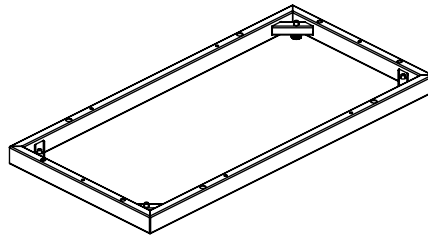
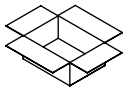
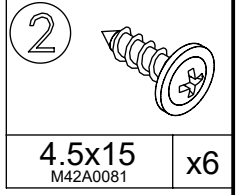
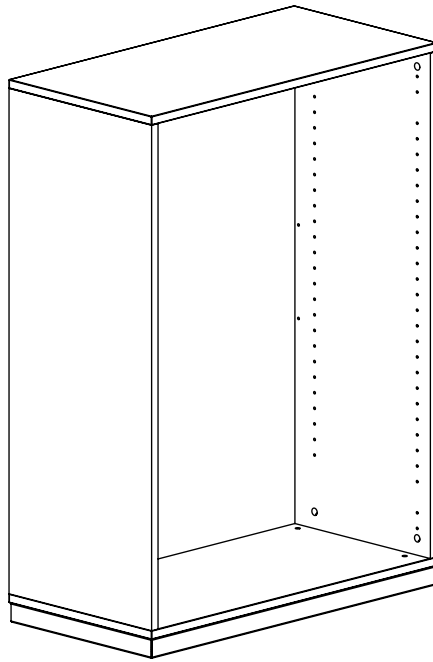
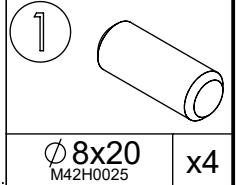
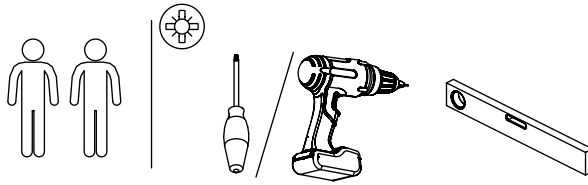

a - x1

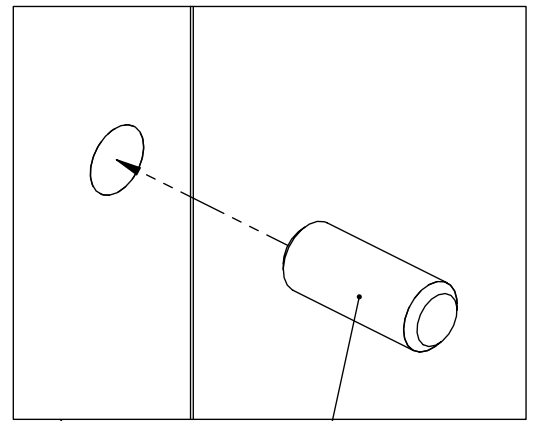
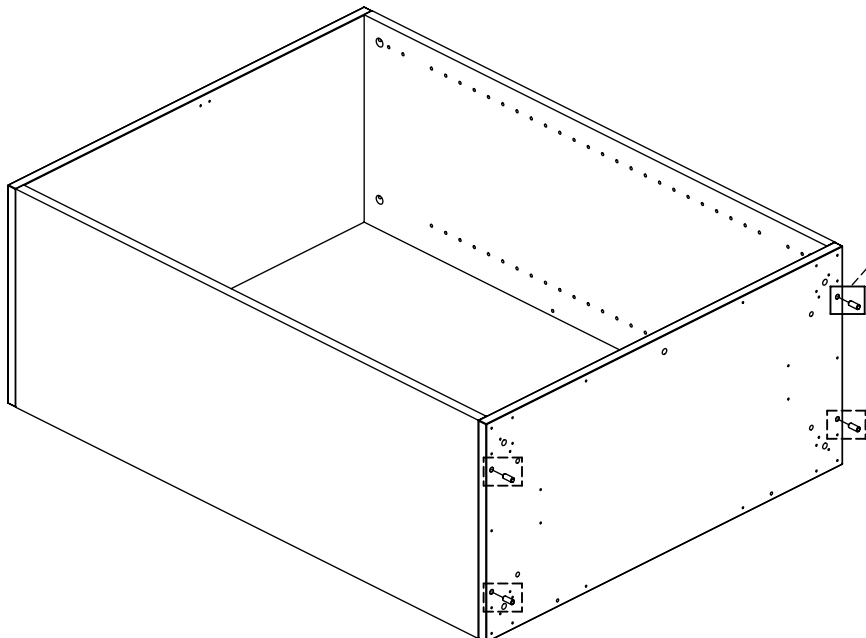

1

2

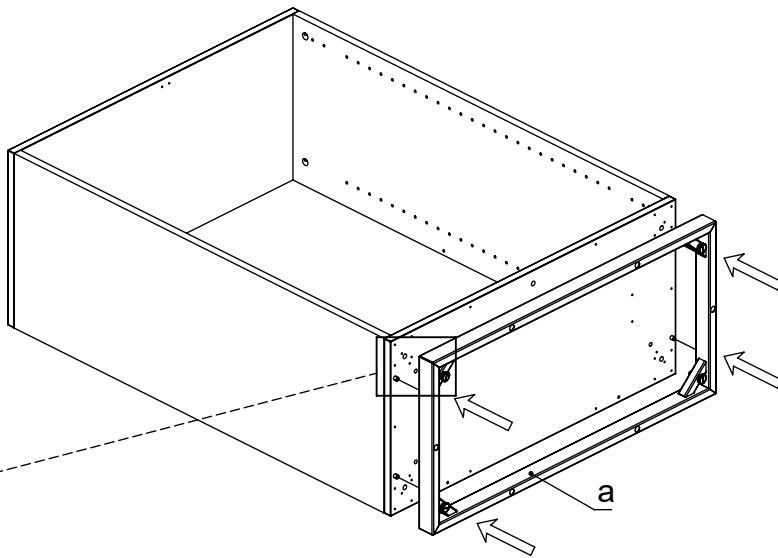
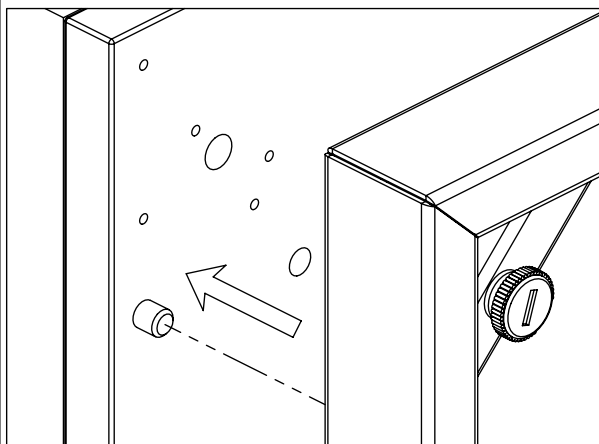

3

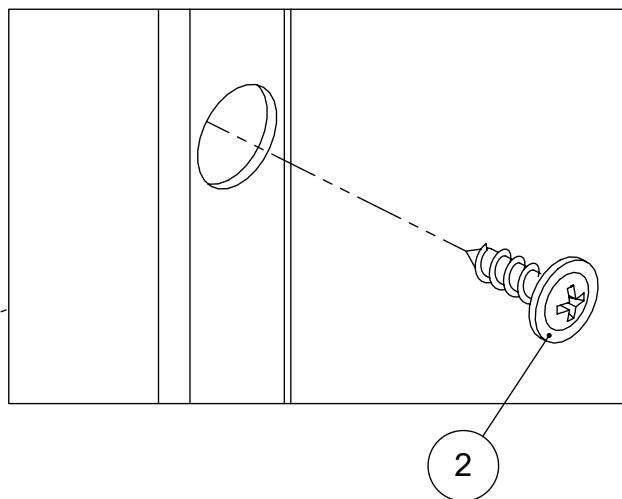
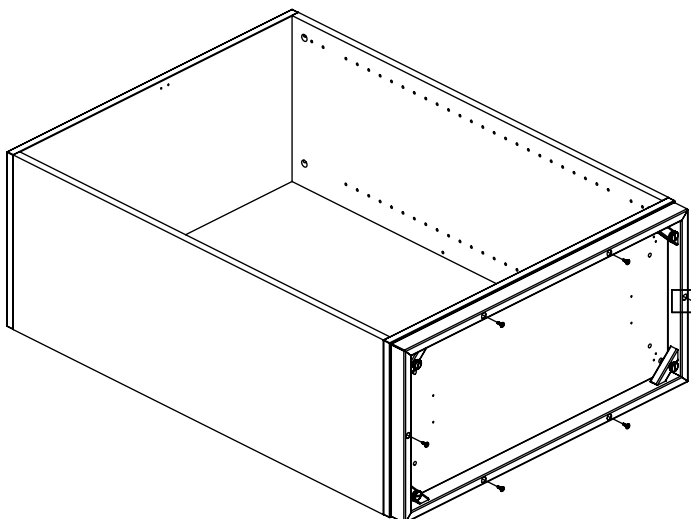



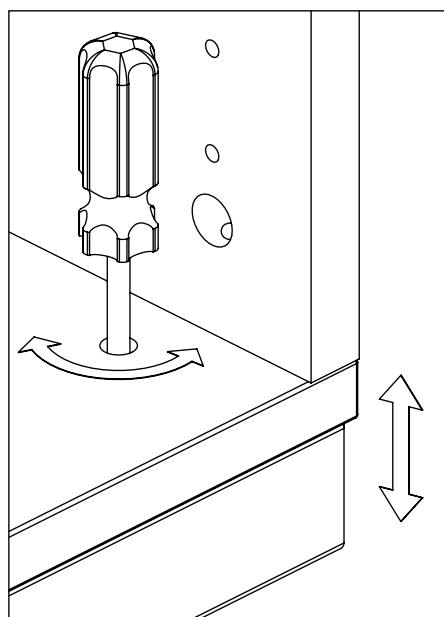
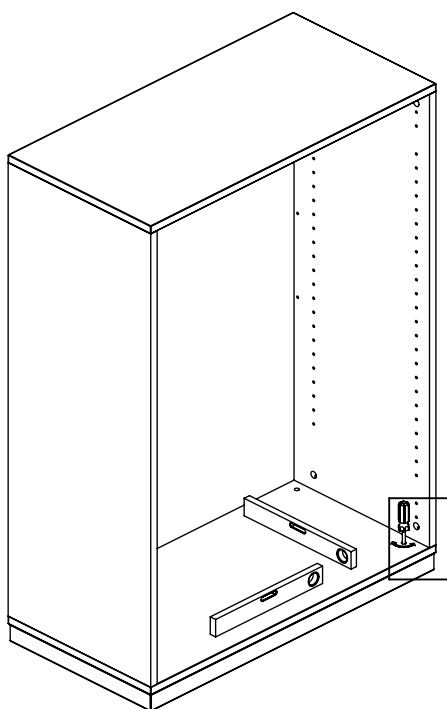

\*



# COMBUS

EN Assembly scheme | DE Aufbauanleitung | FR Schéma d'assemblage

 00:10	 x1	  
--	--	---

instructions.narbutas.com

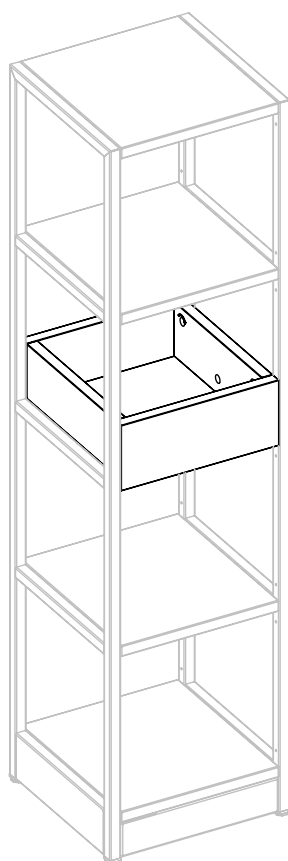

Example of the combination. Specific combination (wide, height, storage components type) depends on order option and chosen components.



Beispiel für eine Kombination. Die konkrete Kombination (Breite, Höhe, Art der Ablagen) hängt von der Wahl der Komponenten und den Bestelloptionen ab.

Exemple de combinaison. La combinaison spécifique (largeur, hauteur, type d'éléments de rangement) dépend de l'option de commande et des éléments choisis.

Sets of storage components can be chosen individually and placed in various positions upon assembly. Instructions for other options provided with their packaging.



Die Sets der Ablageelemente können individuell ausgewählt und bei der Montage in verschiedenen Positionen platziert werden. Die Anleitungen für andere Optionen liegen den jeweiligen Packungen bei.

Les jeux d'éléments de rangement peuvent être choisis individuellement et placés dans différentes positions lors de l'assemblage. Les instructions pour les autres options sont fournies dans leur emballage.

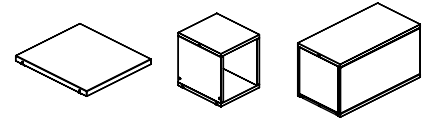

Units sizes

Größe der Einheit

Taille de l'unité

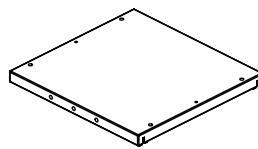
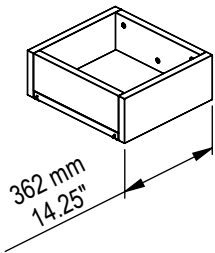
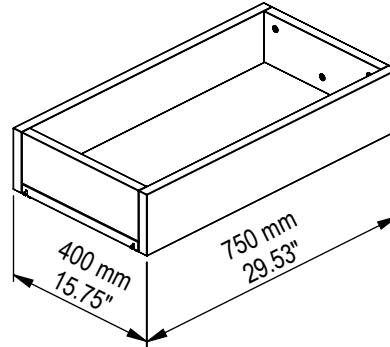
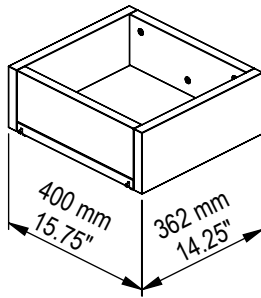

a - x1

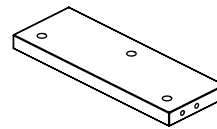

b - x2

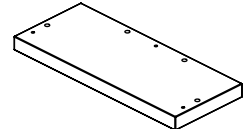

c - x2



M42B0002

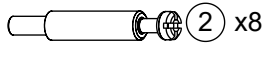

5/11x34  
M42B0022

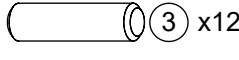

Ø8x30  
M42H0001

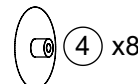

M45A3x

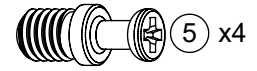

M6x7.8  
M42C0406

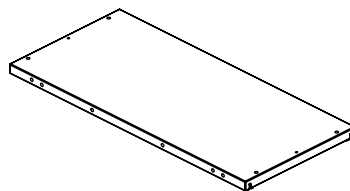
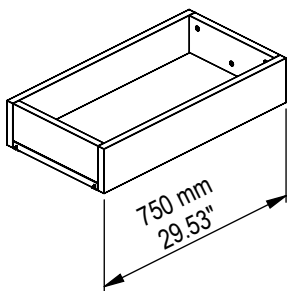

a - x1

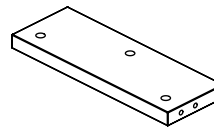

b - x2

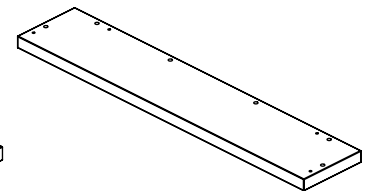

c - x2



M42B0002

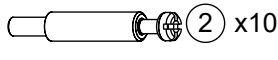

5/11x34  
M42B0022

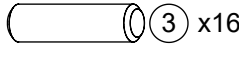

Ø8x30  
M42H0001

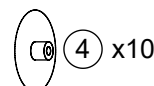

M45A3x

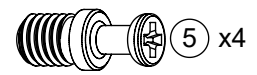

M6x7.8  
M42C0406



# 1

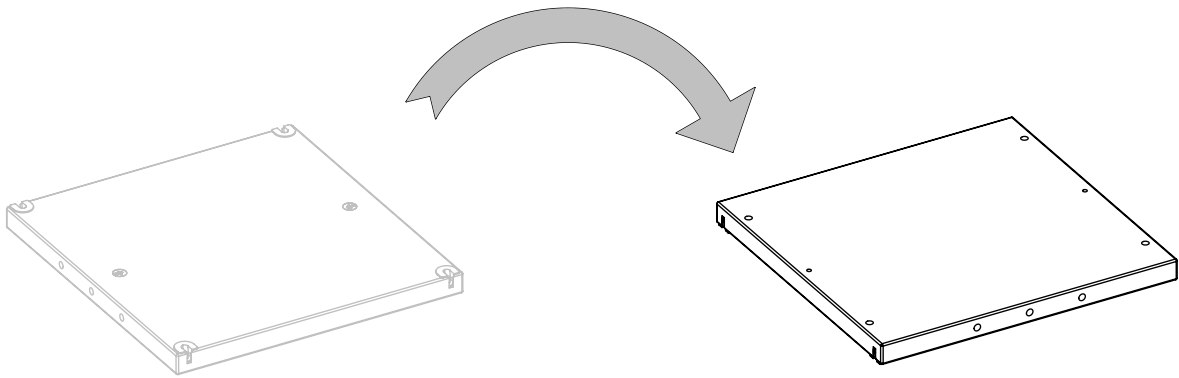
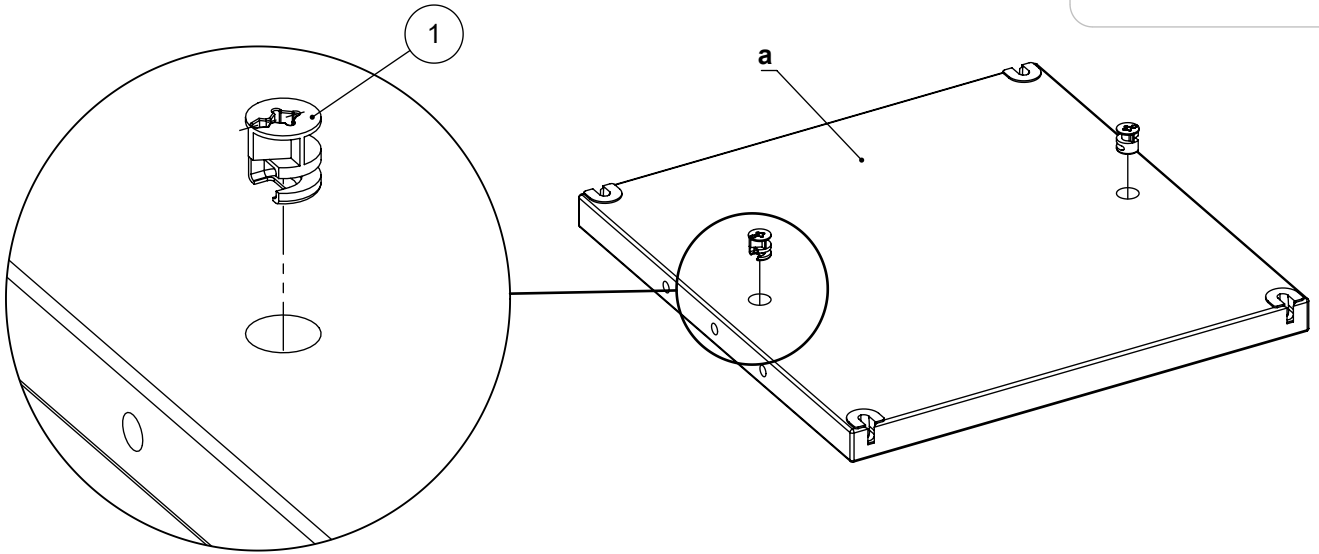
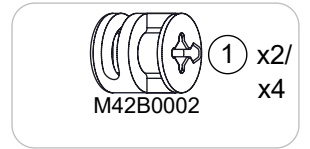

# 2

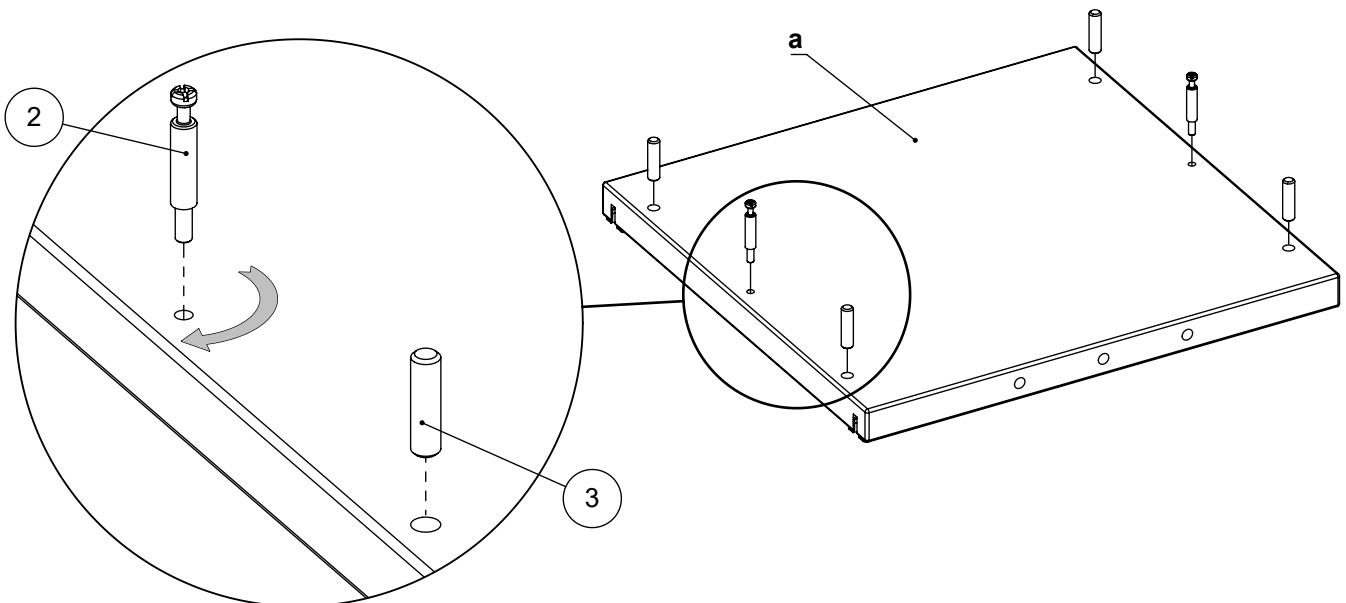
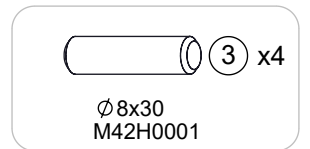
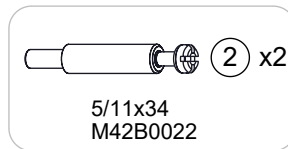

# 3

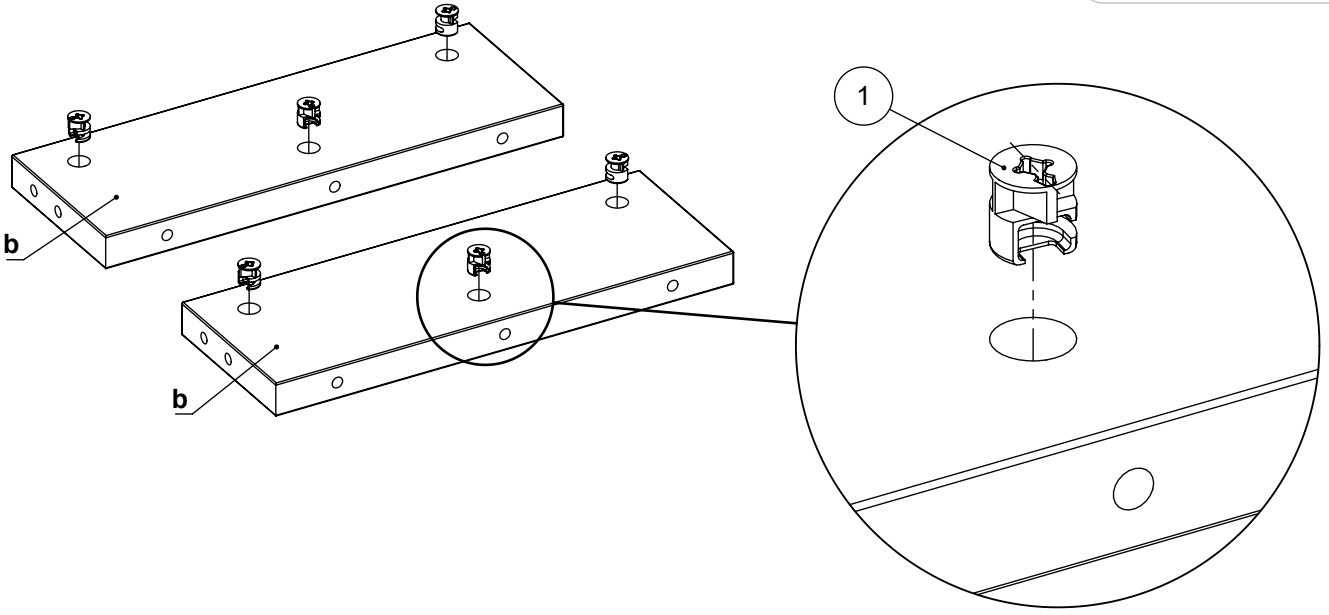
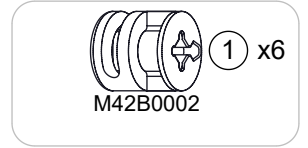

# 4

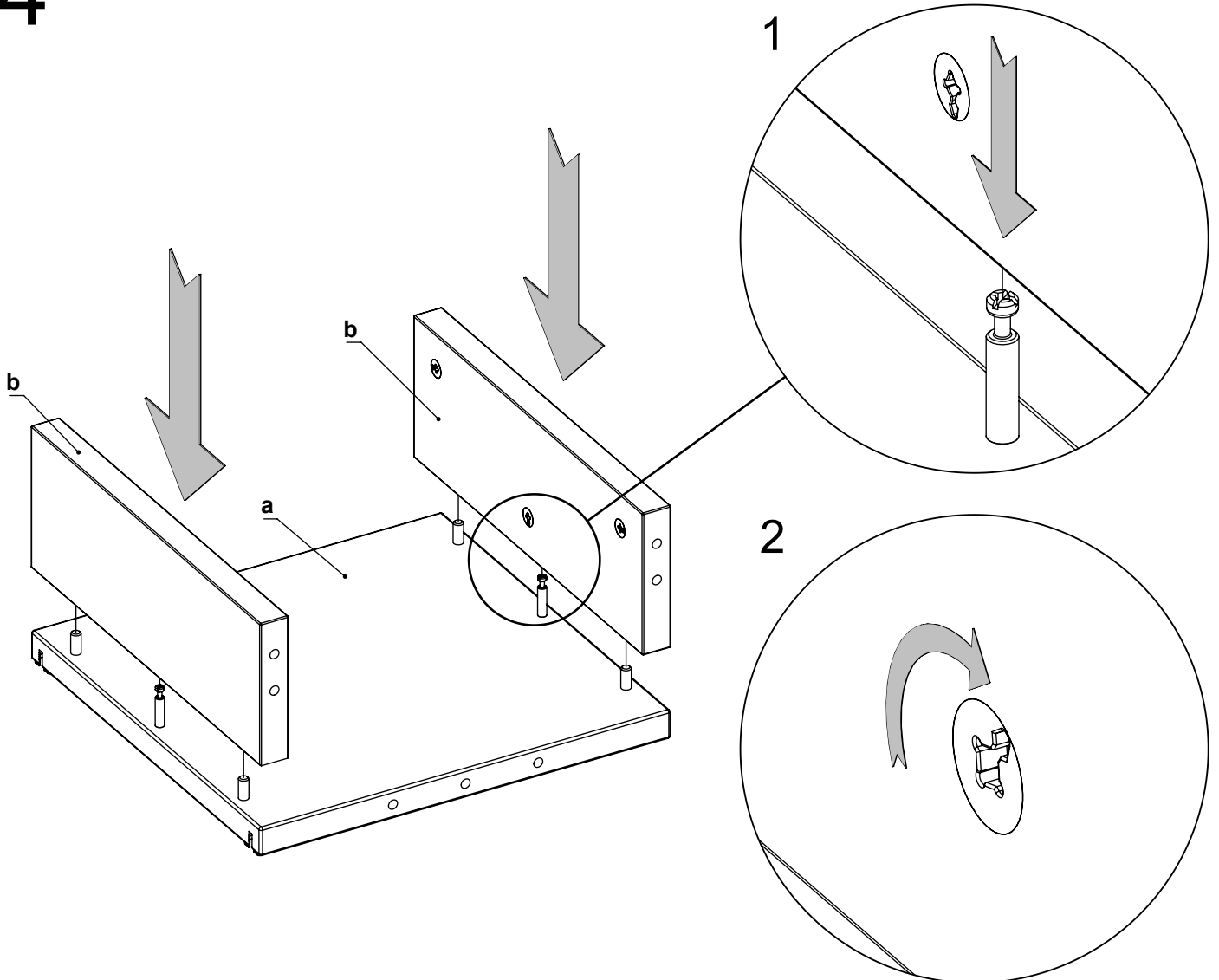

# 5

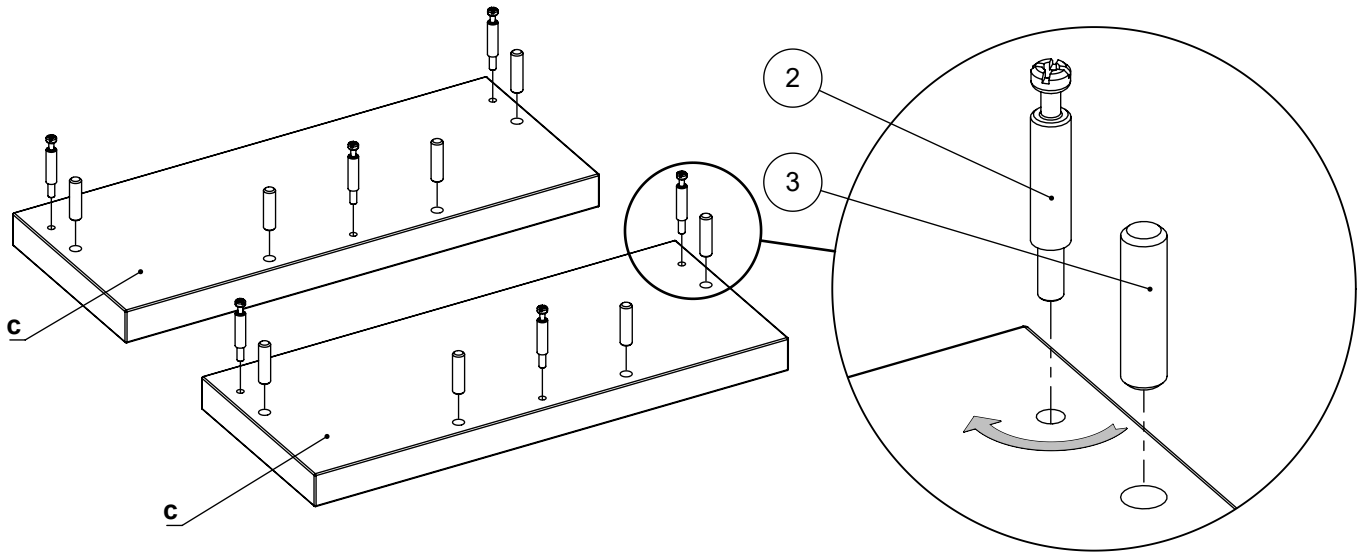
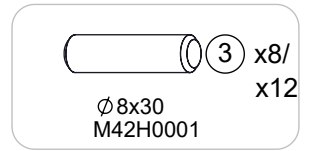
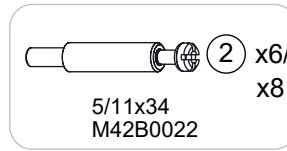

# 6

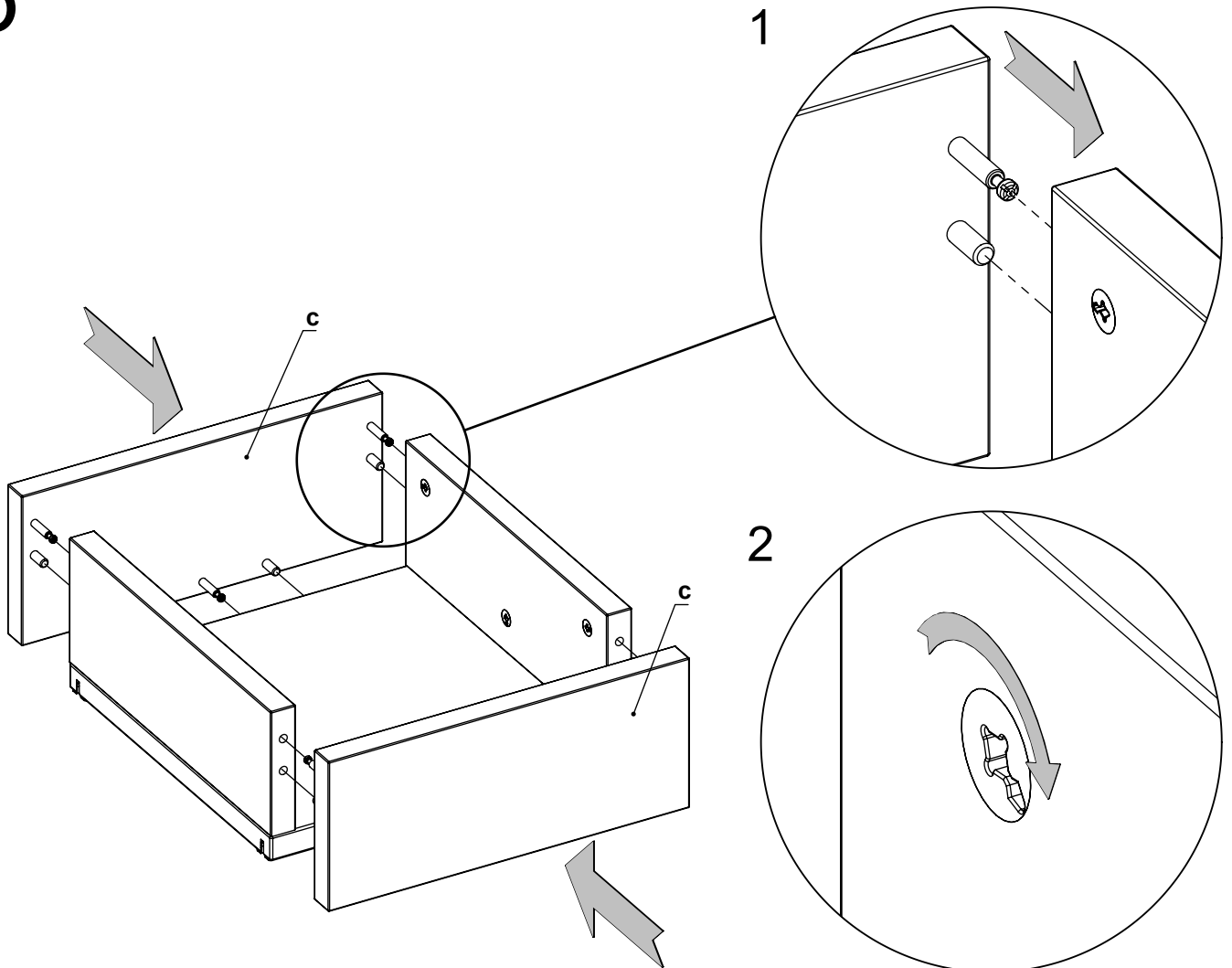

# 7

M45A3x 4 x8/  
x10

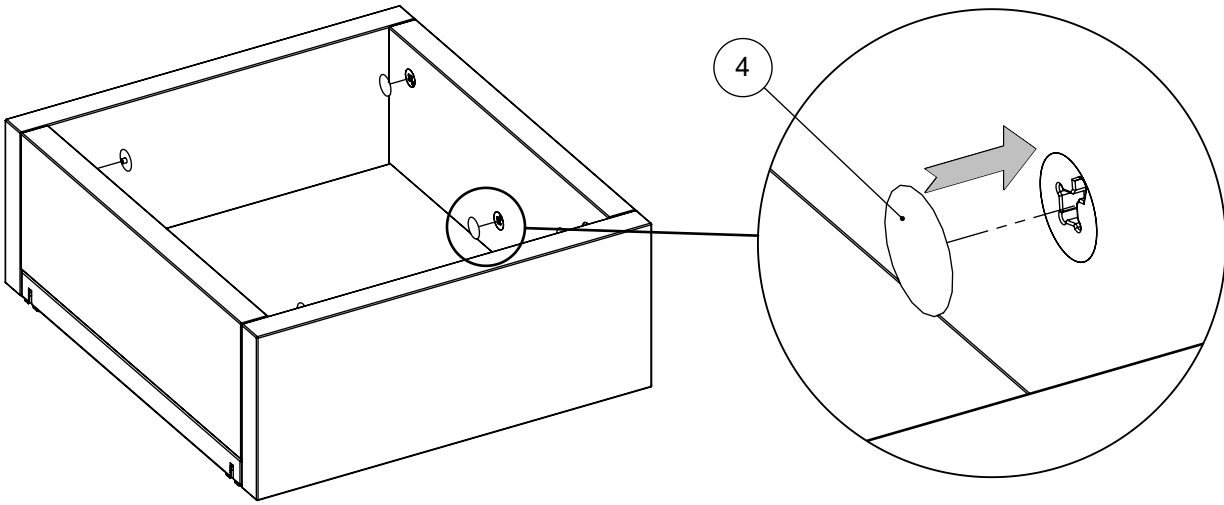

**a** For planter box installation at 1H level, check the a part of these instructions.  
Für die Montage der Blumenkiste auf der Höhe 1H den Teil a diese Anleitung beachten.  
Pour l'installation d'une jardinière au niveau 1H, voir la partie x de ces instructions.

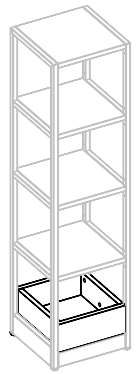

**a.1** Use the template\*  
Vorlage nutzen\*  
Utiliser le modèle\*

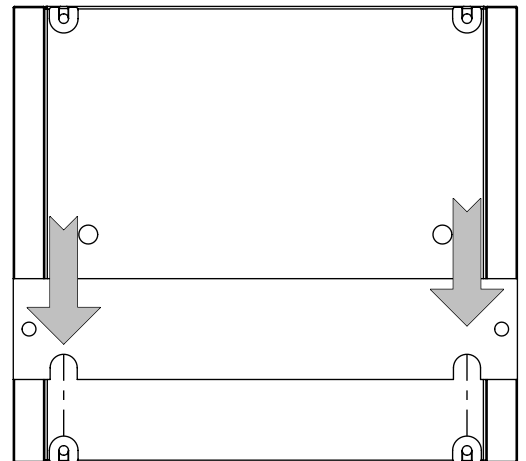
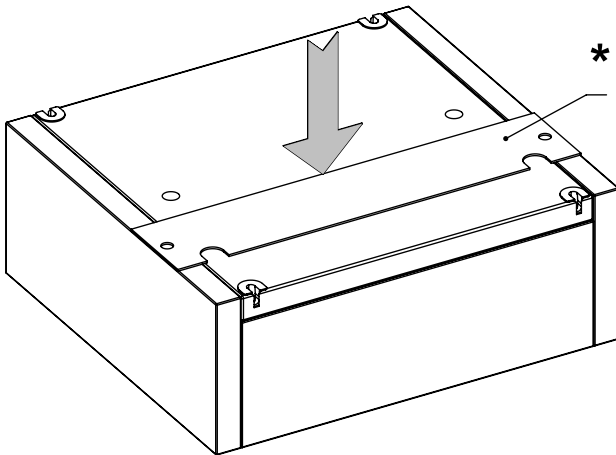

**\*** Template is provided with plinth package.  
Die Vorlage wird mit der Packung des Sockels geliefert.  
Le modèle est fourni avec un paquet de plinthes.

# a.2

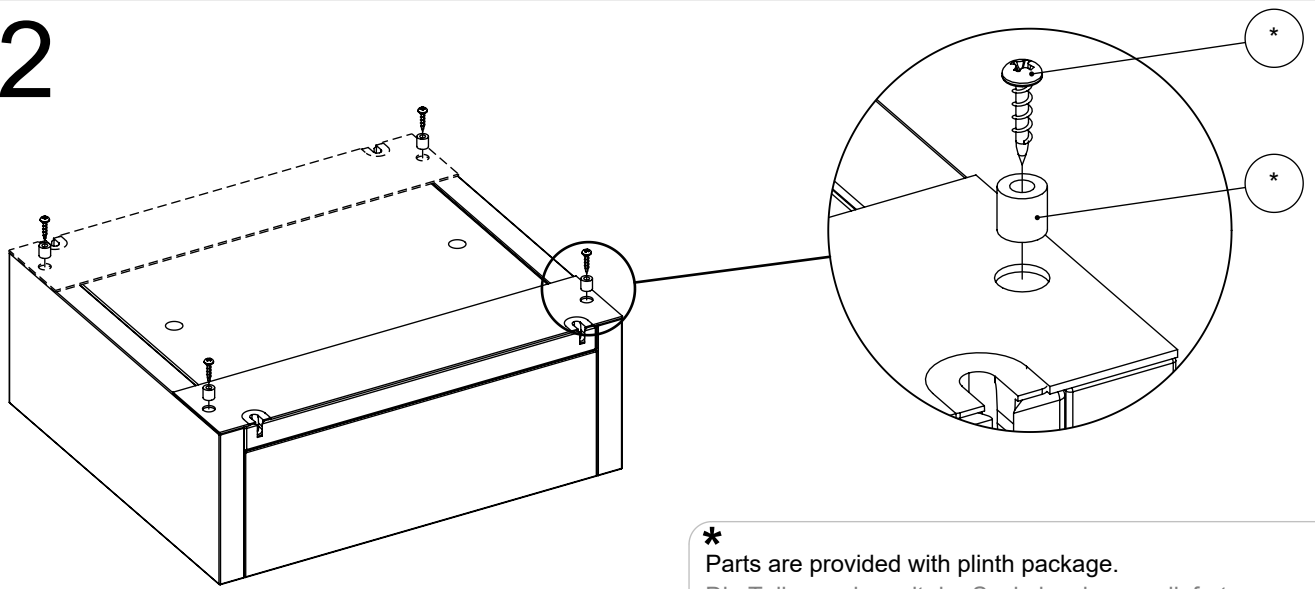

\*  
Parts are provided with plinth package.  
Die Teile werden mit der Sockelpackung geliefert.  
Les pièces sont fournies avec un paquet de plinthes.

# a.3

Remove the template  
Vorlage entfernen  
Retirer le modèle

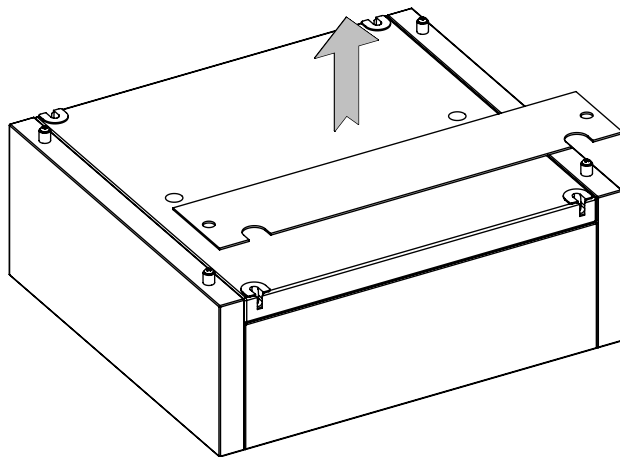

# a.4

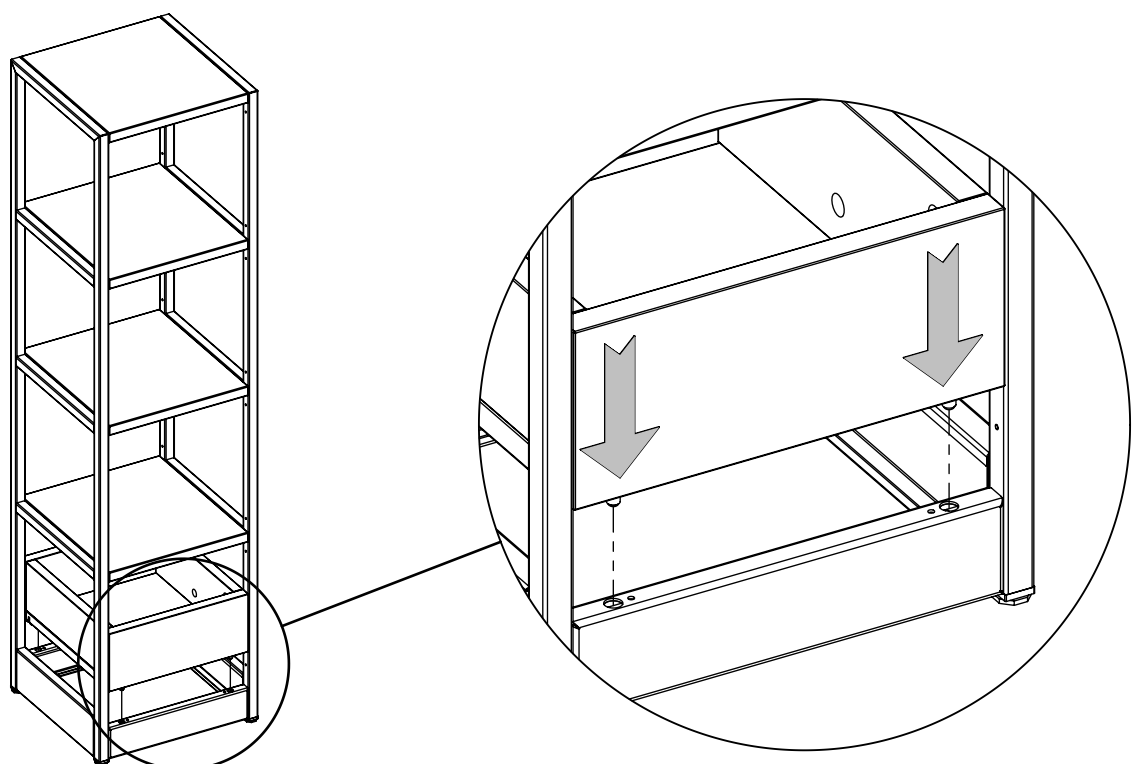

**b** For planter box installation at 2H or higher level, check the b part of these instructions.  
Für die Montage der Blumenkiste auf der Höhe 2H oder höher den Teil b diese Anleitung beachten.  
Pour l'installation d'une jardinière au niveau 2H ou supérieur, voir la partie b de ces instructions.

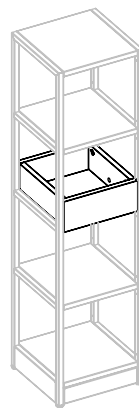

## b.1

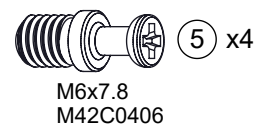
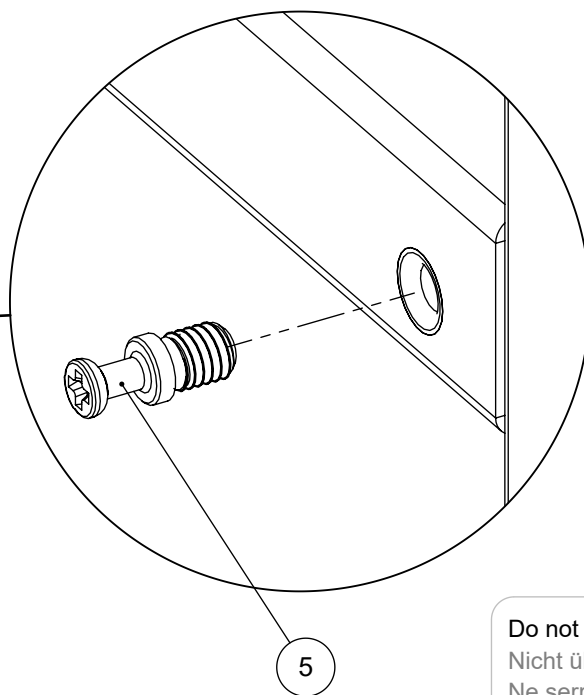
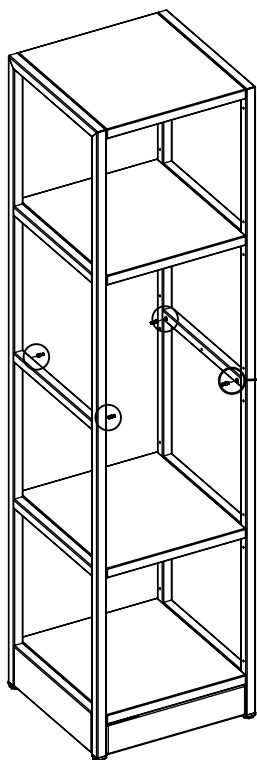

Do not overtighten  
Nicht überdrehen  
Ne serrez pas trop les vis



## b.2

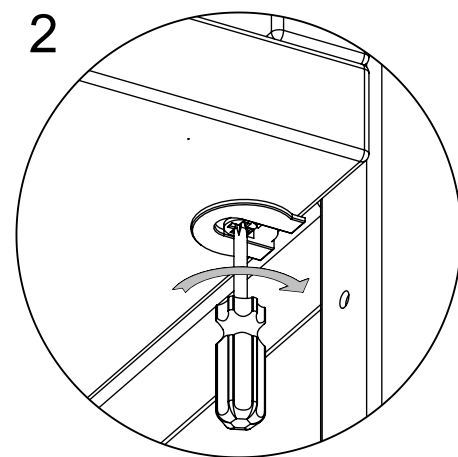
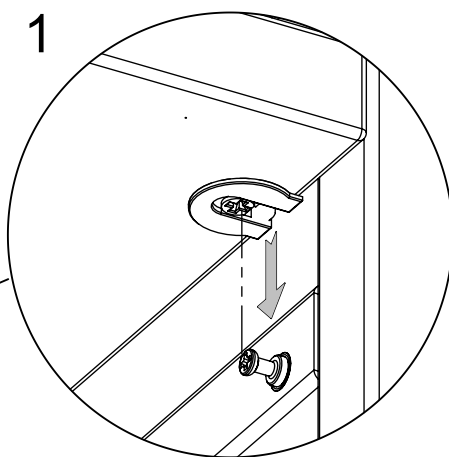
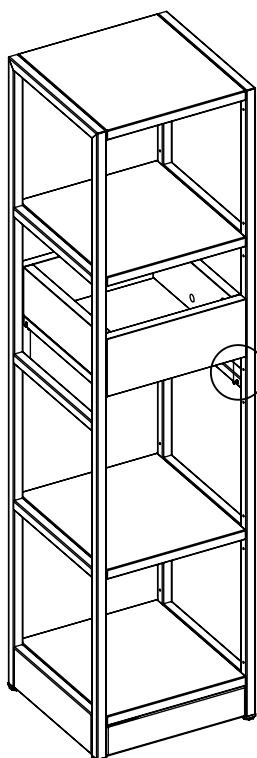

# COMBUS

EN Assembly scheme | DE Aufbauanleitung | FR Schéma d'assemblage

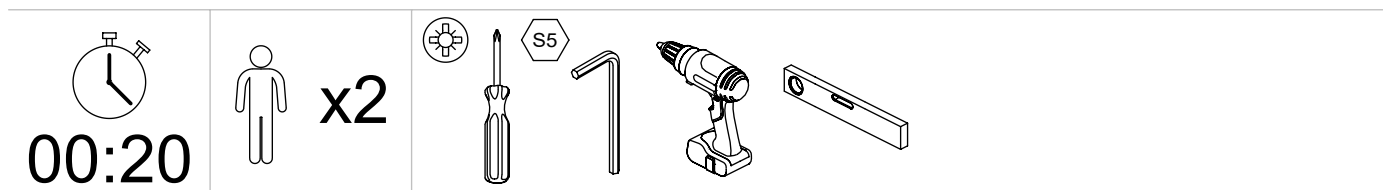

instructions.narbutas.com

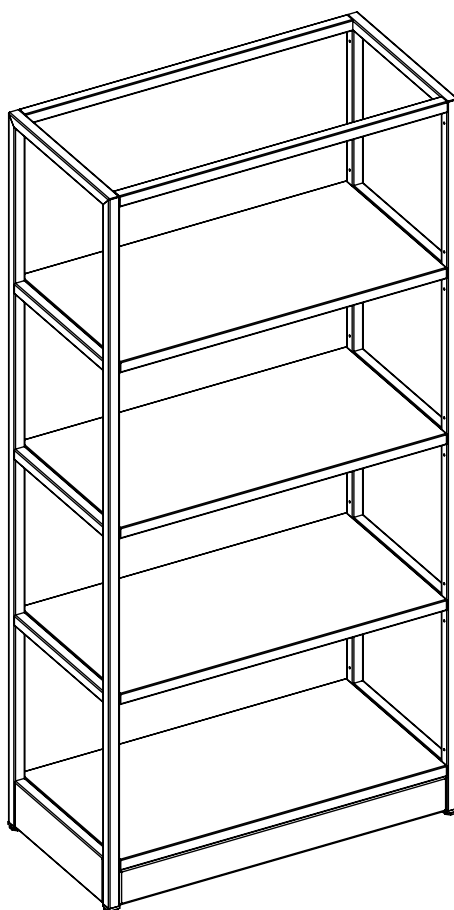

Example of the combination. Specific combination (wide, height, storage components type) depends on order option and chosen components.



Beispiel für eine Kombination. Die konkrete Kombination (Breite, Höhe, Art der Ablagen) hängt von der Wahl der Komponenten und den Bestelloptionen ab.

Exemple de combinaison. La combinaison spécifique (largeur, hauteur, type d'éléments de rangement) dépend de l'option de commande et des éléments choisis.

Unit size  
Größe der Einheit  
Taille de l'unité

# a - 3H

# b - 4H

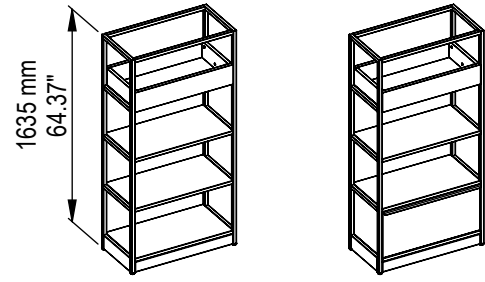
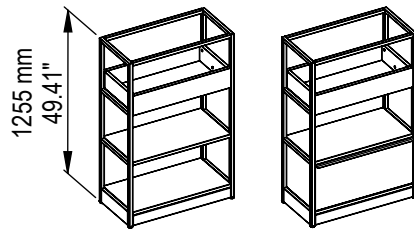

Set of storage components could be chosen individually and placed in various positions upon assembly. Instructions for other options provided with other packages.

Die Sets der Ablageelemente können individuell ausgewählt und bei der Montage in verschiedenen Positionen platziert werden. Die Anleitungen für andere optionale Komponenten liegen den jeweiligen Packungen bei.

Les jeux d'éléments de rangement peuvent être choisis individuellement et placés dans différentes positions lors de l'assemblage. Les instructions pour les autres éléments de rangement sont fournies dans leur emballage.

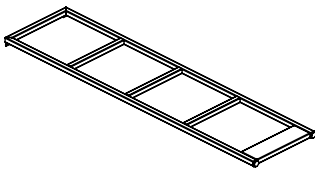
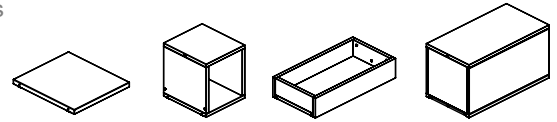
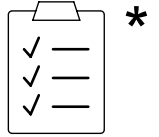

a - x2



b - x2



c - x2



d - x2



e - x2

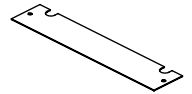

f - x1

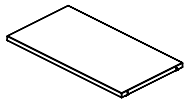

g - x\*

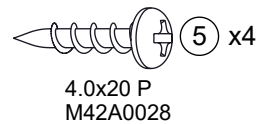
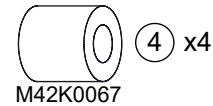
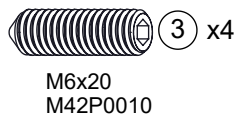
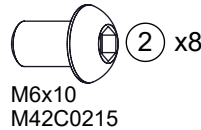
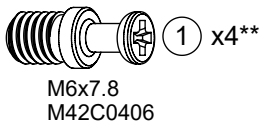

\*\*  
4 pcs/shelve  
4 Stück/Regal  
4 pièces/étagère



# Stability requirements | Stabilitätsanforderungen | Exigences de stabilité

It is always recommended to fix COMBUS storage system to the wall or the floor, considering there is a tip over risk.



## Compulsory measures to ensure furniture stability:

Height	Combination options	Compulsory measures	Additional limitations
2H	Planter box	- Fixing to the floor	Standing next to the wall Recommended for freestanding units
3H	Shelves and box	- Fixing to the floor	Standing next to the wall Recommended for freestanding units
	Box and drawer	a) Counterweights (12 kg or 26.5 lb for one drawer) b) Fixing to the wall of floors	1) Drawer installed not higher than 2H level. 2) Not more than 1 drawer per column. 1) Drawer installed not higher than 2H level. 2) Not more than 1 drawer per column.
4H	Shelves and box	- Fixing to the floor	Standing next to the wall Recommended for freestanding units
	Shelf, box and drawer	a) Counterweights (12 kg or 26.5 lb for one drawer)	1) Drawer installed not higher than 2H level. 2) Not more than 1 drawer per column.



Es wird empfohlen, eine Kombinationen immer an Wand oder Fußboden zu befestigen, weil sonst das Risiko des Umfallens besteht.



## Obligatorische Maßnahmen für die Stabilität des Möbelstücks:

Höhe	Art der Ablageelemente	Obligatorische Maßnahmen	Zusätzliche Beschränkungen
2H	Blumenkisten	- Befestigen an Fußboden	Aufstellung an der Wand Freie Aufstellung im Raum
3H	Regalböden und Regalboxen	- Befestigen an Fußboden	Aufstellung an der Wand Freie Aufstellung im Raum
	Regalböden und Schubfach	a) Gegengewichte (12 kg für ein Schubfach) b) Befestigen an Wand oder Fußboden	1) Das Schubfach sollte nicht höher als 2H montiert werden 2) Nicht mehr als 1 Schubfach pro Segment 1) Das Schubfach sollte nicht höher als 2H montiert werden 2) Nicht mehr als 1 Schubfach pro Segment
4H	Regalböden und Regalboxen	- Befestigen an Fußboden	Aufstellung an der Wand Freie Aufstellung im Raum
	Regalböden und Schubfach	Gegengewichte (12 kg für ein Schubfach)	1) Das Schubfach sollte nicht höher als 2H montiert werden 2) Nicht mehr als 1 Schubfach pro Segment

Il est toujours recommandé de fixer la combinaison au mur ou au sol, compte tenu d'un risque de basculement.

	<b>AVERIT</b>
	Risque de basculement

**Mesures obligatoires pour assurer la stabilité du mobilier :**

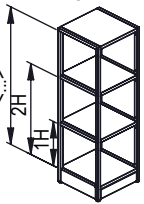
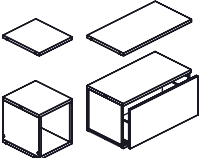
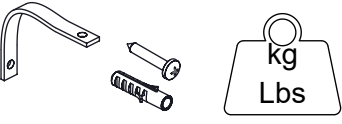
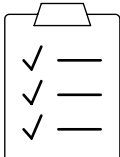
Combinaison large 	Hauteur 	Type d'éléments de rangement 	Mesures obligatoires 
2H	Jardinières	-	Debout à côté du mur
		b) Fixer au sol	Autoportant dans les espaces ouverts
3H	Étagères & caissons d'étagère	-	Debout à côté du mur
		Fixer au sol	Autoportant dans les espaces ouverts
	Étagères & tiroir	a) Contrepoids (12 kg par tiroir) b) Fixer au mur ou au sol	1) Le tiroir ne doit pas être installé plus haut que le niveau 2H. 2) Pas plus d'un tiroir par colonne. 1) Le tiroir ne doit pas être installé plus haut que le niveau 2H. 2) Pas plus d'un tiroir par colonne.
4H	Étagères & caissons d'étagère	-	Debout à côté du mur
	Étagères & tiroir	Fixer au sol Contrepoids (12 kg par tiroir)	Autoportant dans les espaces ouverts 1) Le tiroir ne doit pas être installé plus haut que le niveau 2H. 2) Pas plus d'un tiroir par colonne.

# 1

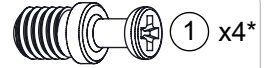

M6x7.8  
M42C0406

\* 4 pcs/shelve  
4 Stück/Regal  
4 pièces/étagère

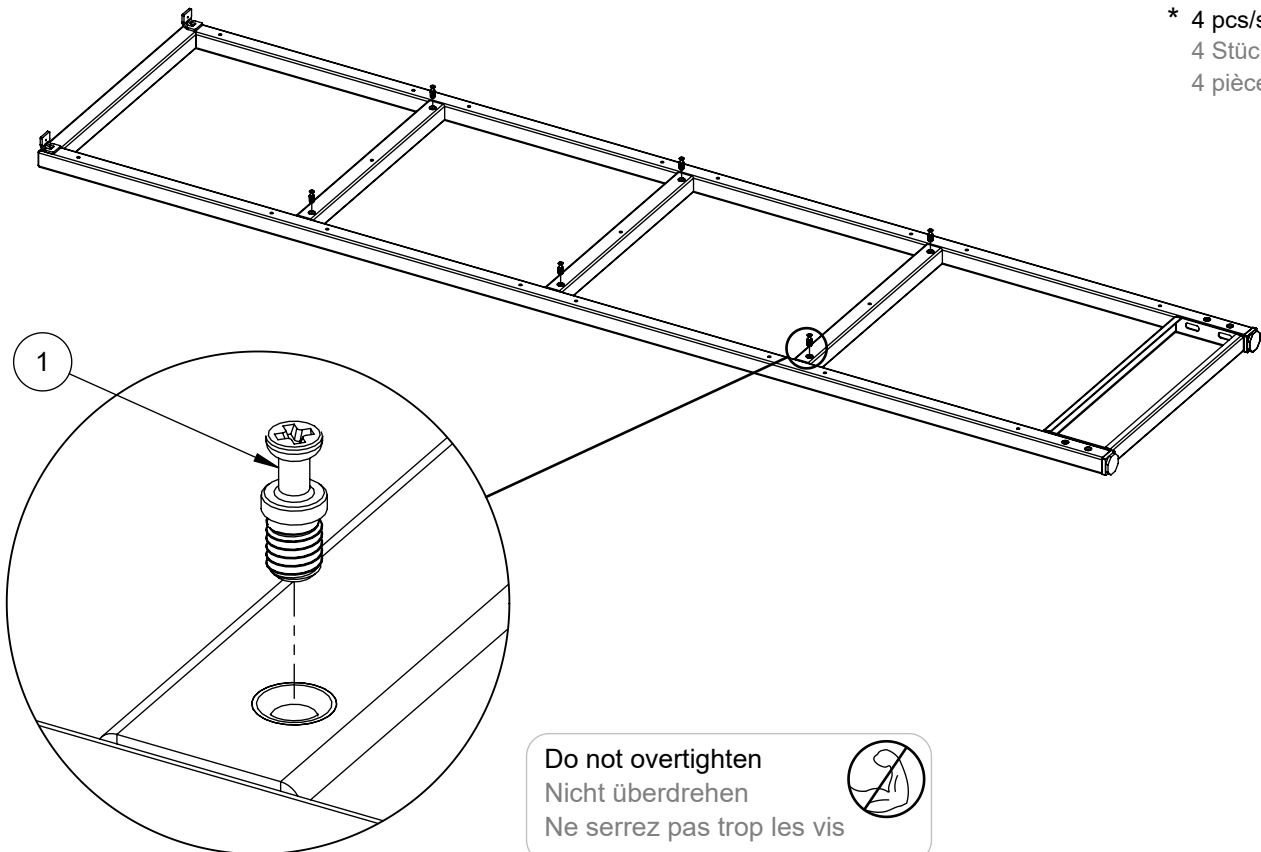

Do not overtighten  
Nicht überdrehen  
Ne serrez pas trop les vis

**i**

Fittings quantity depends on the selected combination and accessories. In some cases fittings should not be installed in each hole (e.g. drawer installation). Please, check the instructions, supplied with supplementary accessories.

Die Menge der Verbindungsstücke hängt von der gewählten Kombination und dem Zubehör ab. In einigen Fällen müssen die Verbindungsstücke nicht in jeder Position montiert werden (z.B. bei Schubfächern). Beachten Sie bitte auch die Anleitungen zu den anderen Komponenten.

Le nombre de raccords dépend de la combinaison et des accessoires choisis. Dans certains cas, les raccords ne doivent pas être installés à chaque position (par exemple, installation d'un tiroir). Veuillez consulter les instructions fournies avec les autres éléments.

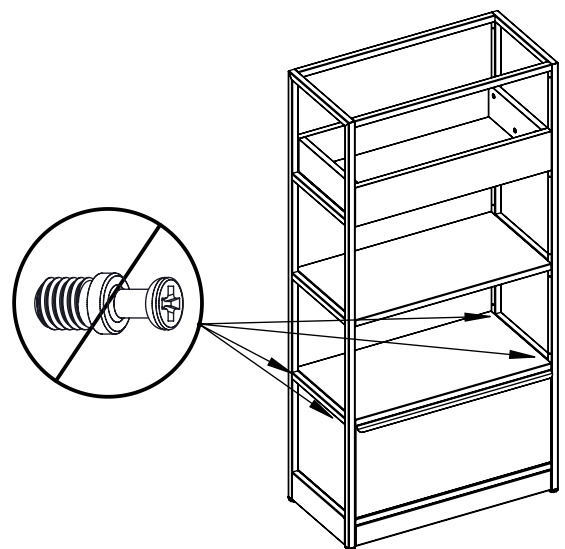

# 2

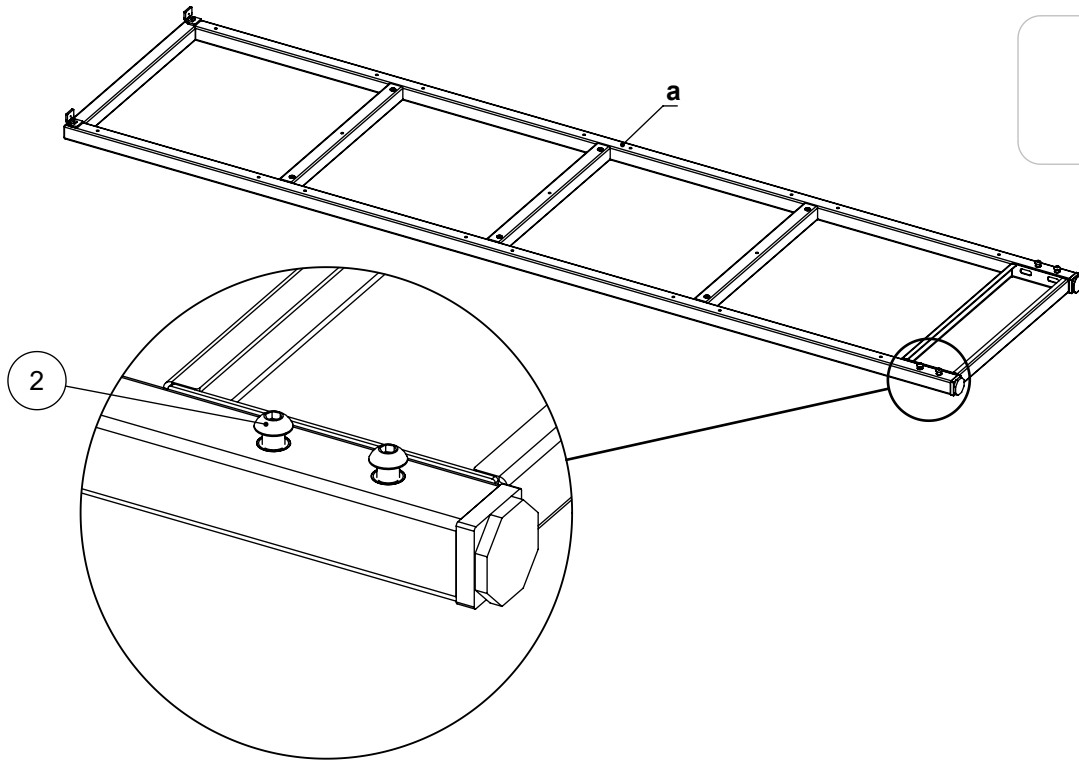

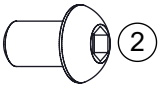
 2 x4  
M6x10  
M42C0215



Do not tighten up  
Nicht festziehen  
Ne serrez pas

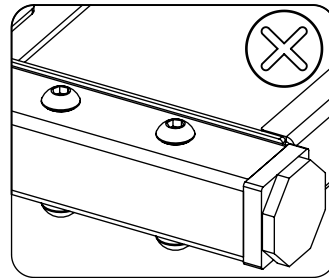
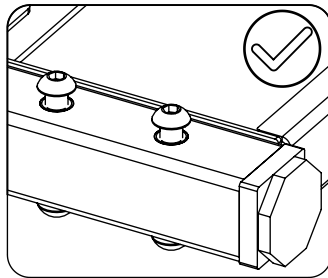

# 3

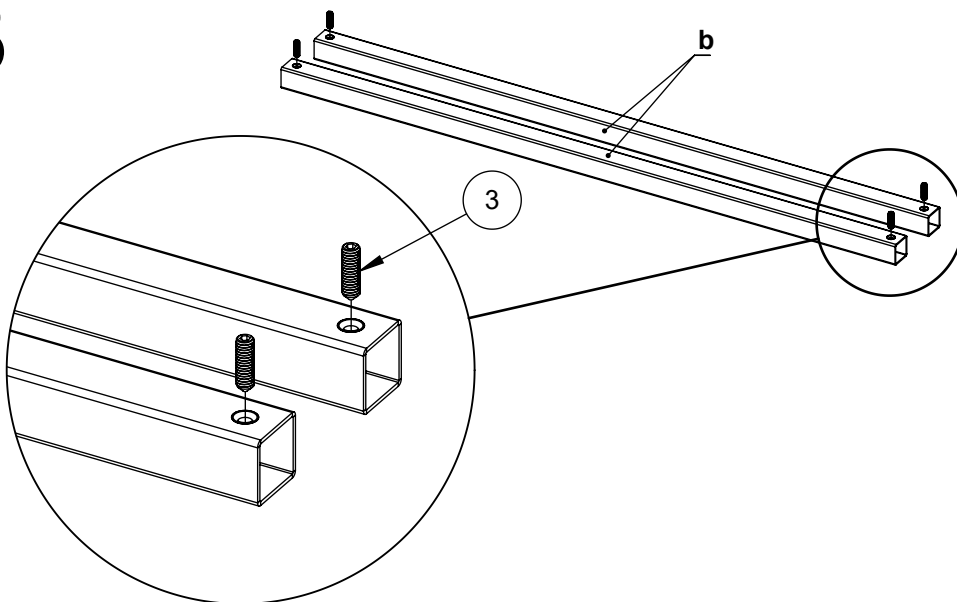

 3 x4  
M6x20  
M42P0010



Do not tighten up  
Nicht festziehen  
Ne serrez pas

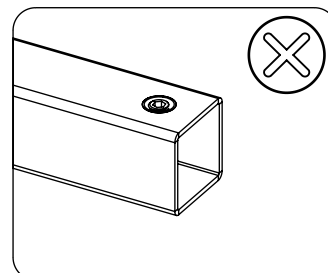
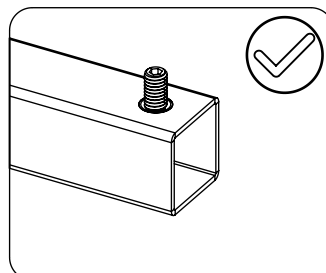

# 4

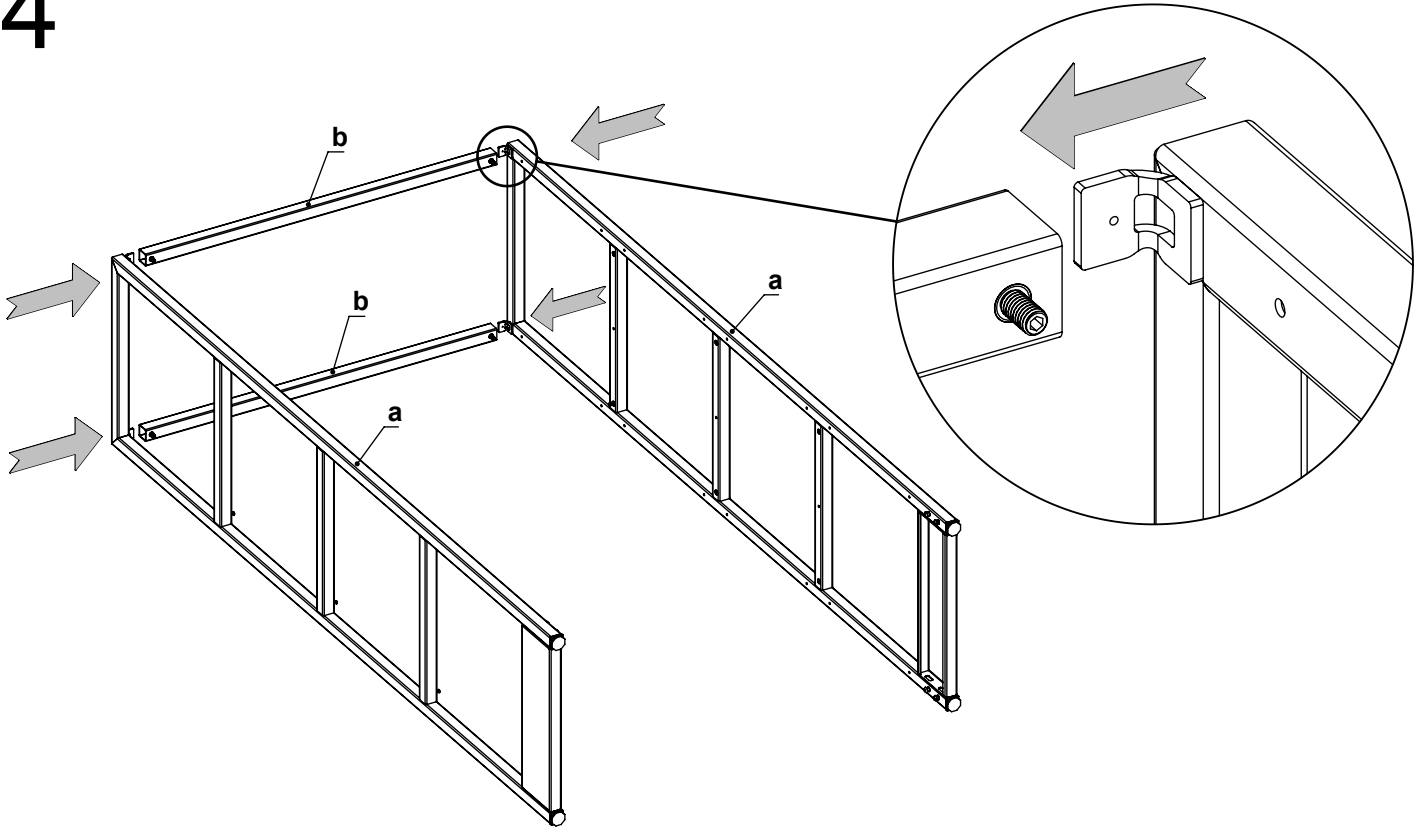

# 5

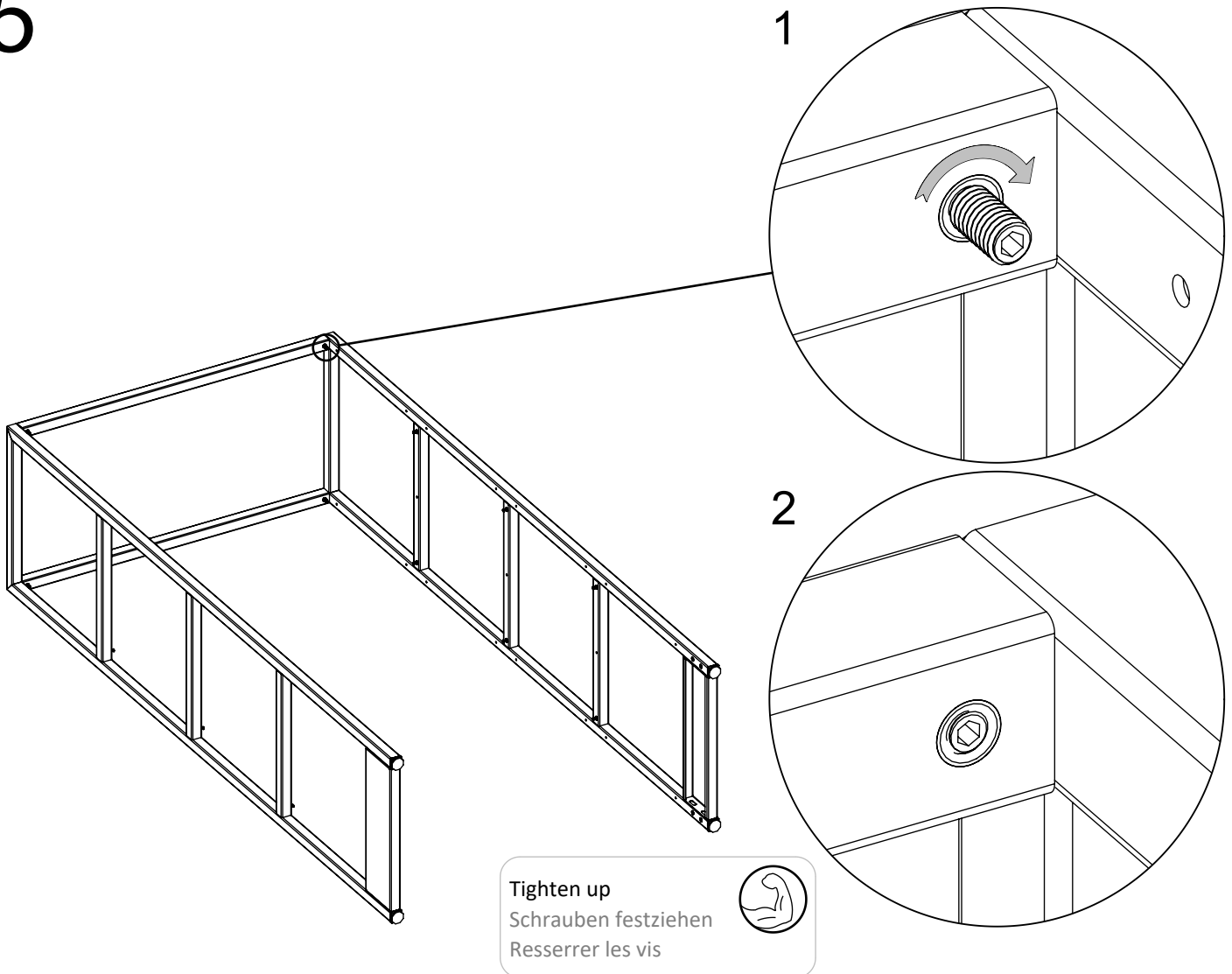

# 6

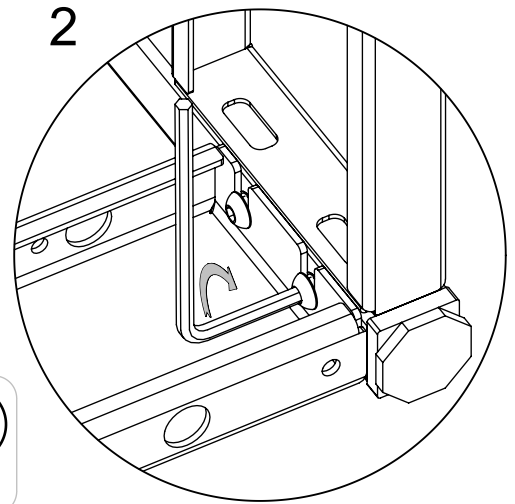
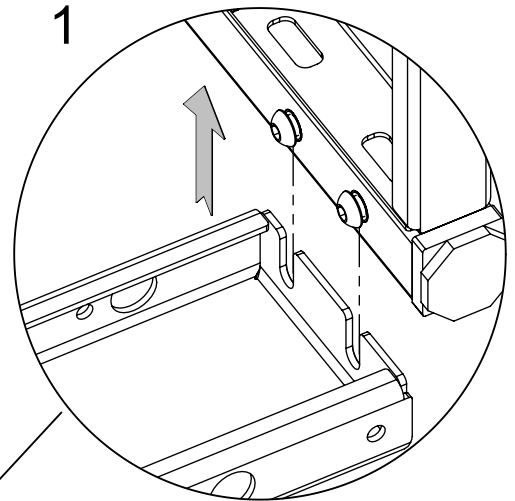
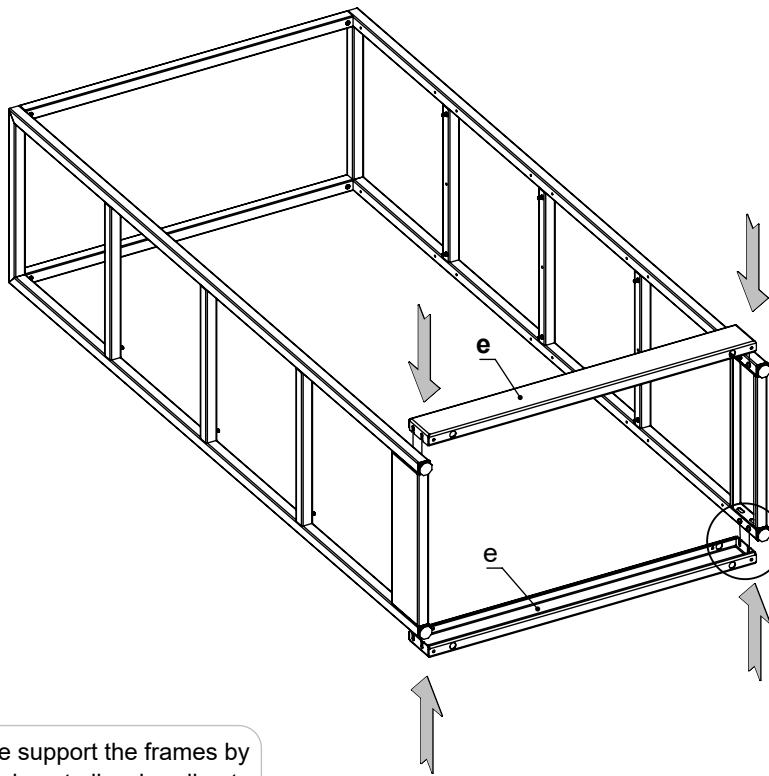

Please support the frames by hand, do not allow bending to the plinth.

Bitte halten Sie die Gestelle fest, damit sie den Sockel nicht verbiegen.

Veuillez maintenir les cadres avec la main, ne les laissez pas plier la plinthe.

Tighten up  
Schrauben festziehen  
Resserrer les vis



**a** For units, standing next to the wall, check the a part of these instructions.  
Für Einheiten, die an der Wand aufgestellt werden, Teil a der Anleitung beachten.  
Pour les unités placées à côté du mur, voir la partie a de ces instructions.

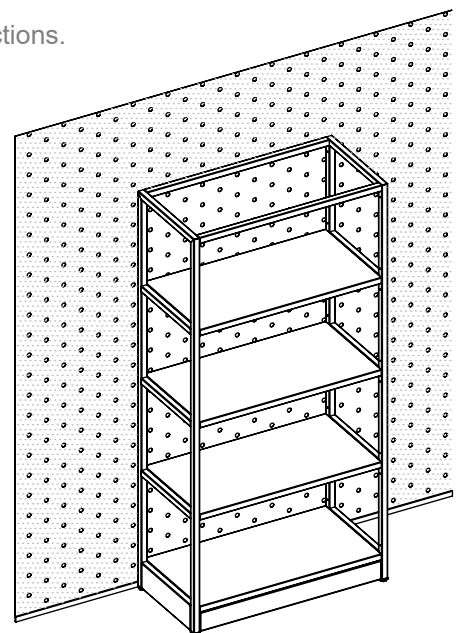

# a.1

5 x4  
4.0x20 P  
M42A0028

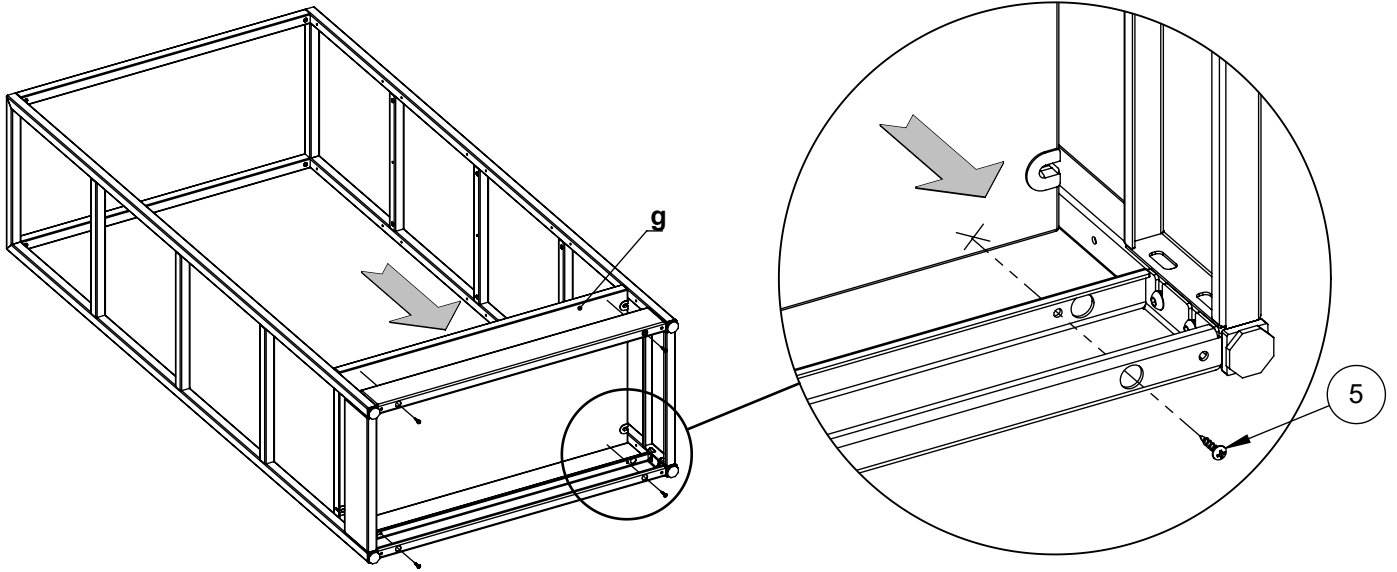

# a.2

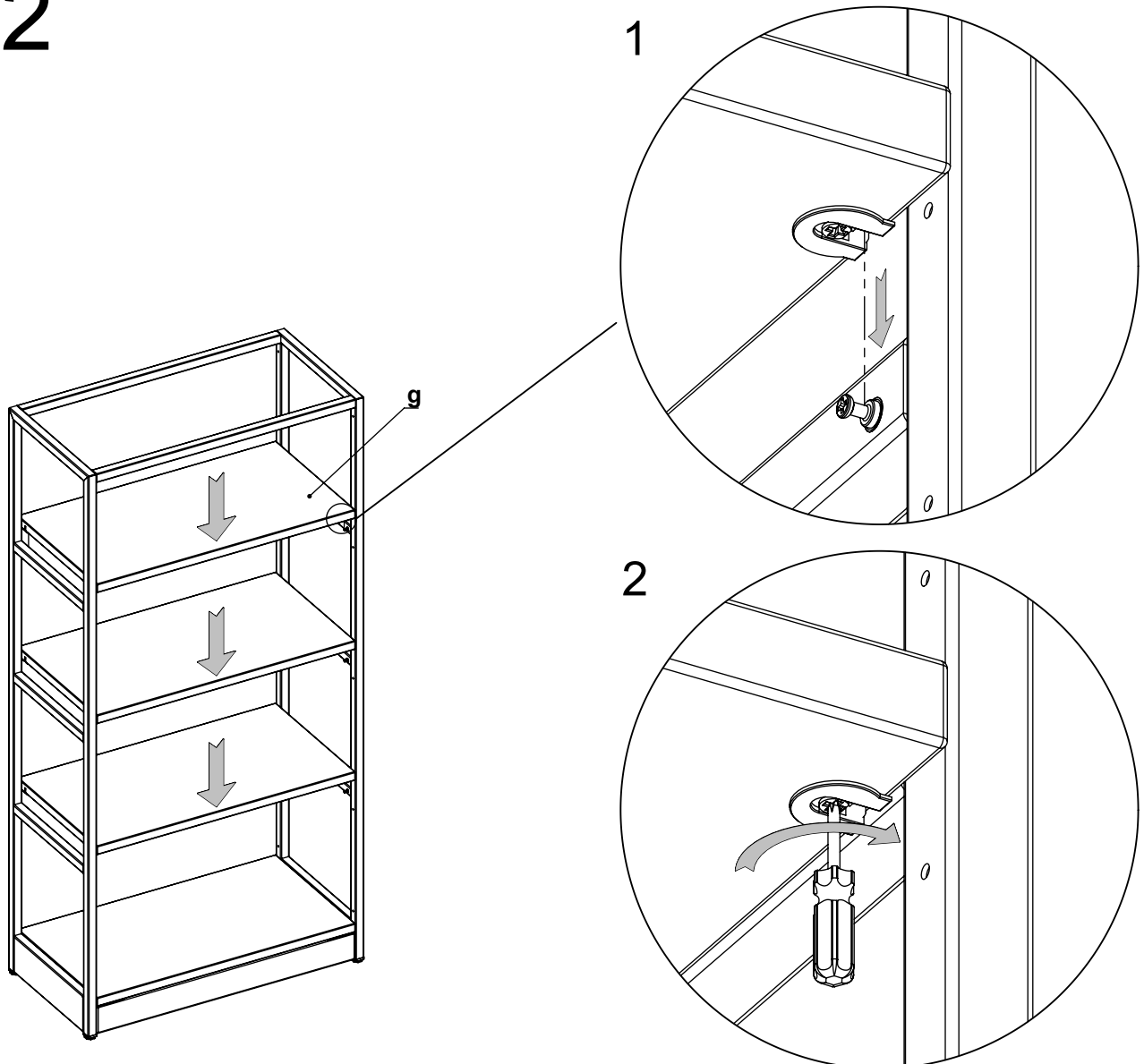

# a.3

Check the alignment  
Überprüfen Sie die Ausrichtung  
Vérifier l'alignement

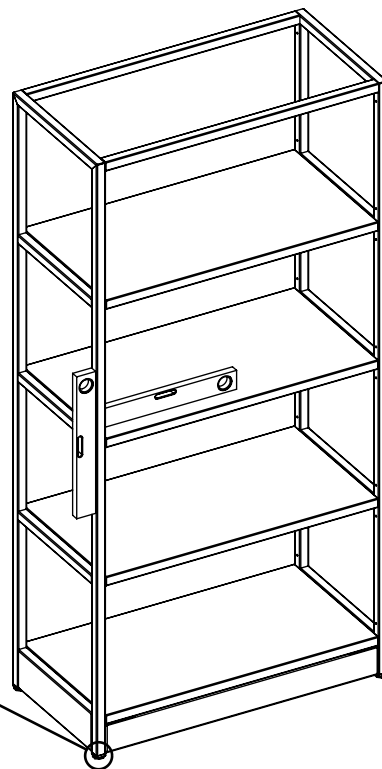
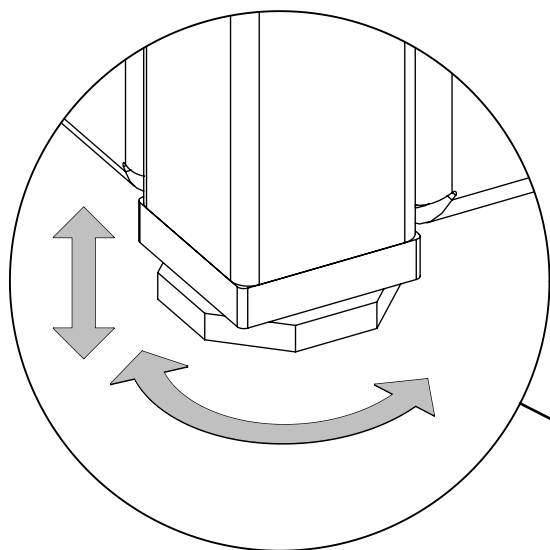
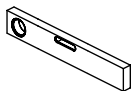

# b

For freestanding units, check the b part of these instructions.  
Für freistehenden Einheiten Teil b der Anleitung beachten.  
Pour les unités autoportantes, voir la partie b de ces instructions.

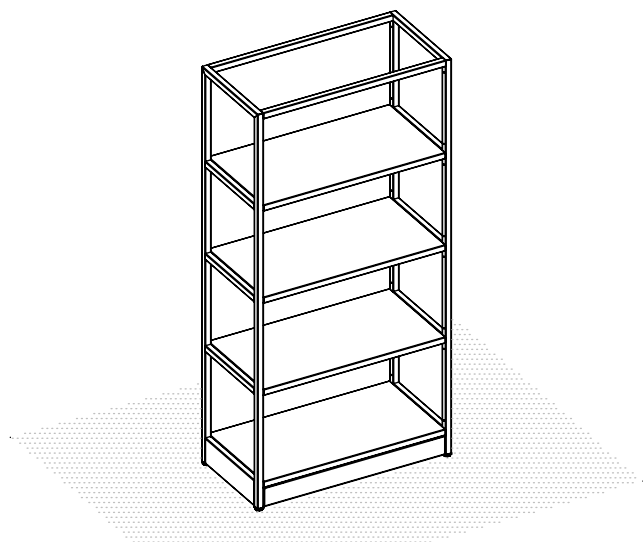

# i

Check the stability requirements at the page 3. If necessary, fix the combination to the floor, according to the b steps. Combination should be fixed at the corners, according to the example below.

Beachten Sie bitte die Anforderungen zur Stabilität auf Seite 3. Wenn erforderlich, die Kombination gemäß Schritt b auf dem Fußboden befestigen. Die Kombination muss wie im nachstehenden Beispiel an den Ecken befestigt werden.

Vérifier les exigences de stabilité page 3. Si nécessaire, fixer la combinaison au sol, conformément à l'étape b. La combinaison doit être fixée aux angles, conformément à l'exemple ci-dessous.

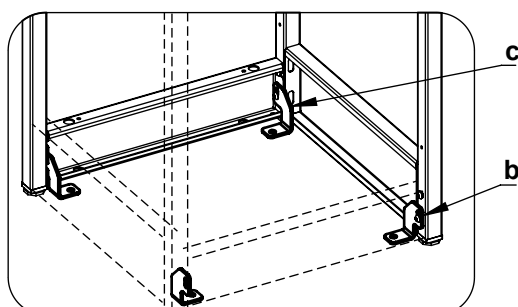



**i**

Anchors should be selected according to the floor type. We recommend to use M8x115/45 anchors for concrete floors. If necessary, please consult with local construction specialist.

Die Befestigungselemente sind je nach Fußbodentyp auszuwählen. Wir empfehlen für Betonböden die Benutzung von Bolzenankern M8x115/45. Wenn notwendig, ziehen Sie einen lokalen Fachmann hinzu.

Les chevilles doivent être choisies en fonction du type de sol. Nous recommandons d'utiliser des chevilles M8x115/45 pour les sols en béton. Si nécessaire, veuillez consulter un professionnel local de la construction.

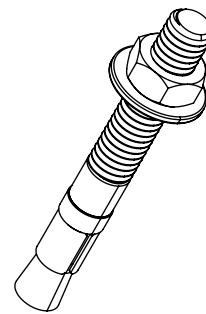

## b.1

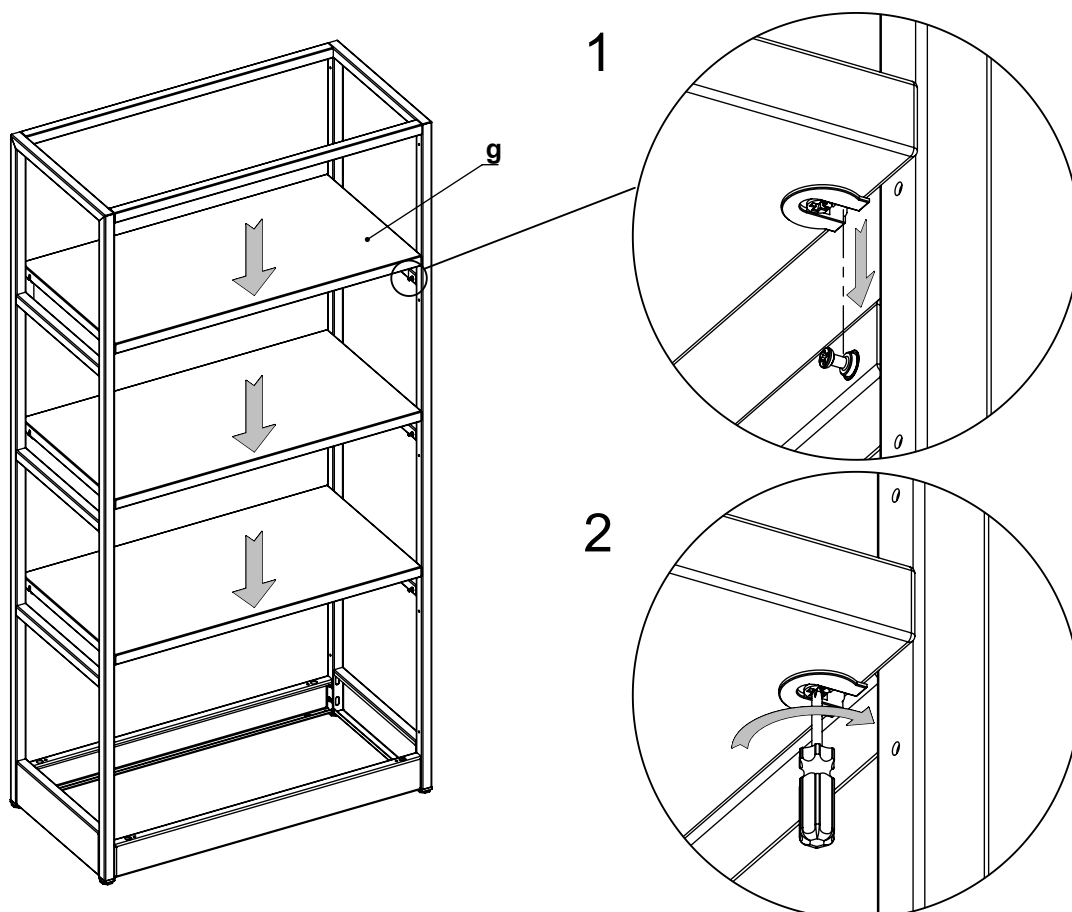

## b.2

Check the alignment  
Überprüfen Sie die Ausrichtung  
Vérifier l'alignement

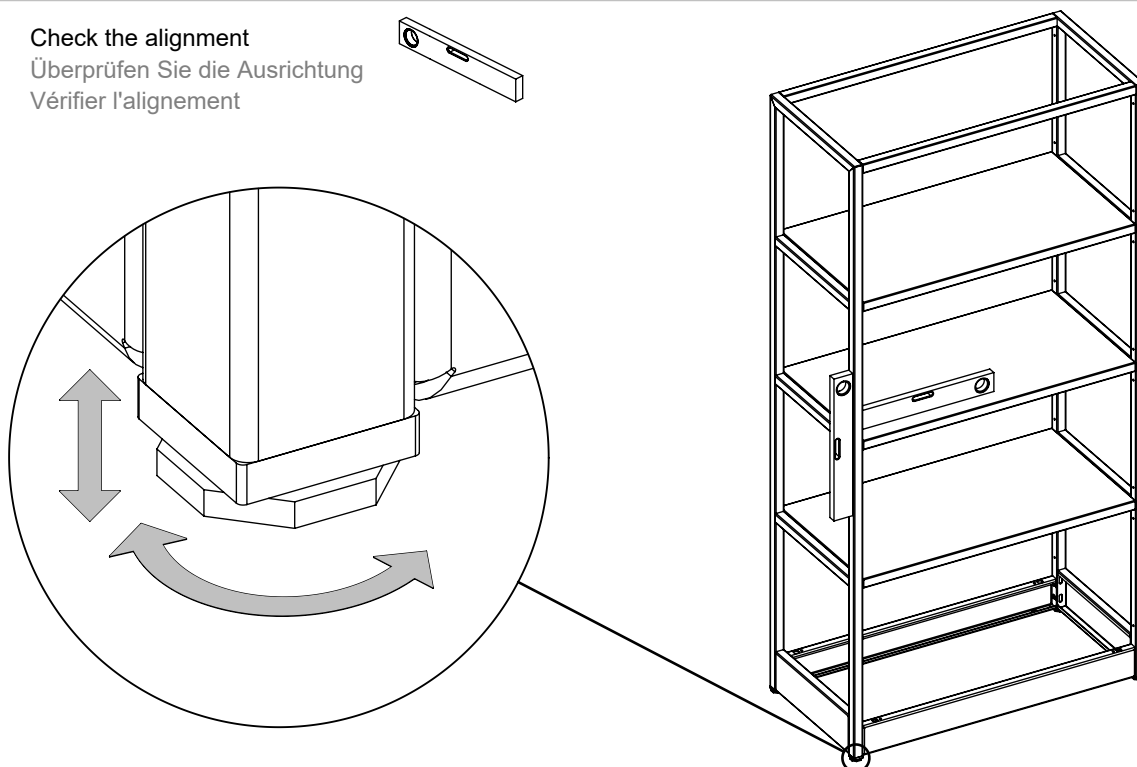
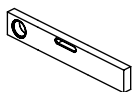

# b.3

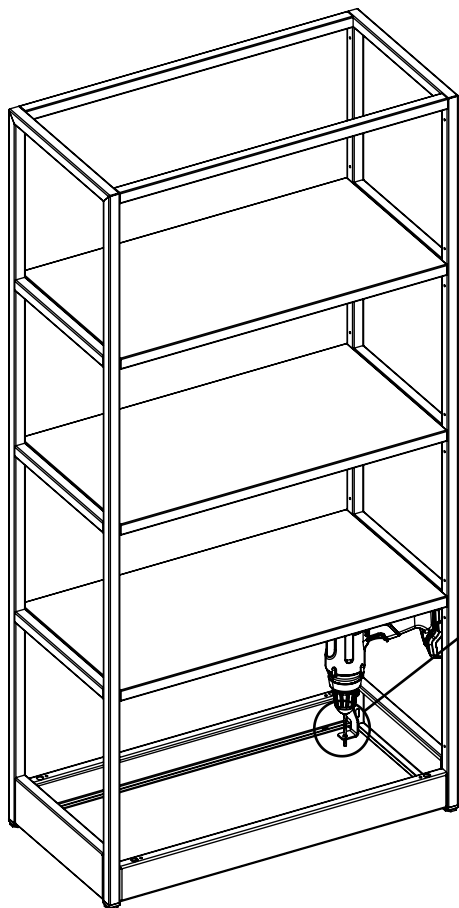

1

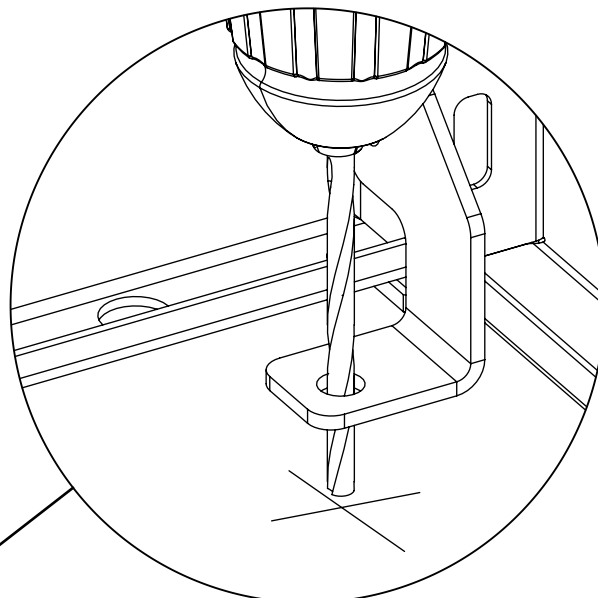

2 Unscrew (2) screw, and tighten up bracket.  
Schraube (2) lösen und die Halterung festziehen.  
Dévisser la vis (2) et serrer le support.

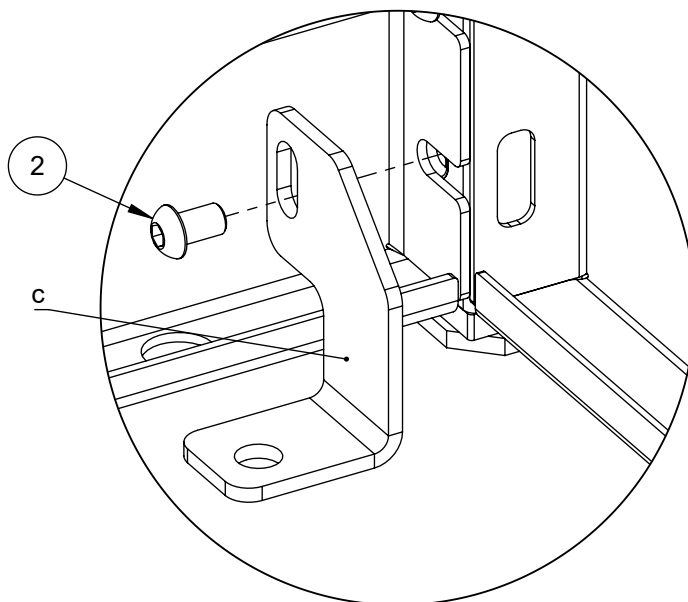

3

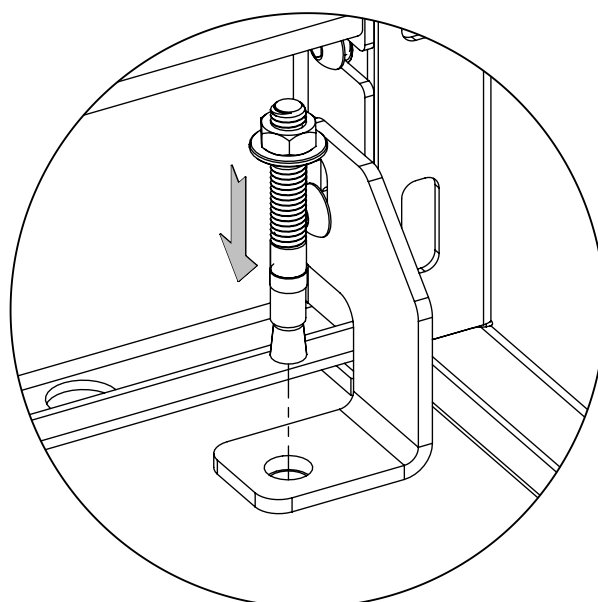

# b.4

Use the template  
Vorlage nutzen  
Utiliser le modèle

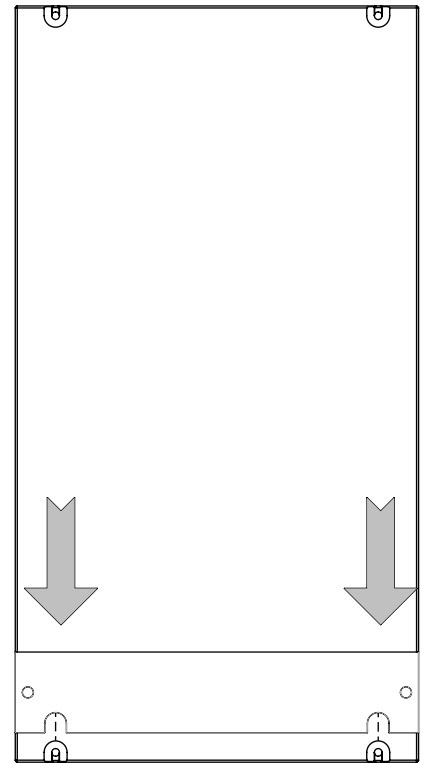
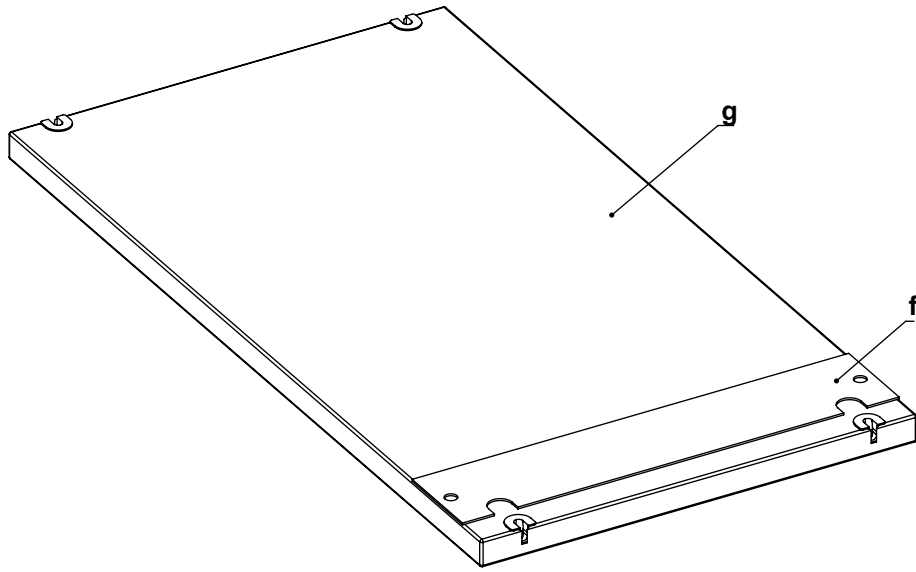

# b.5

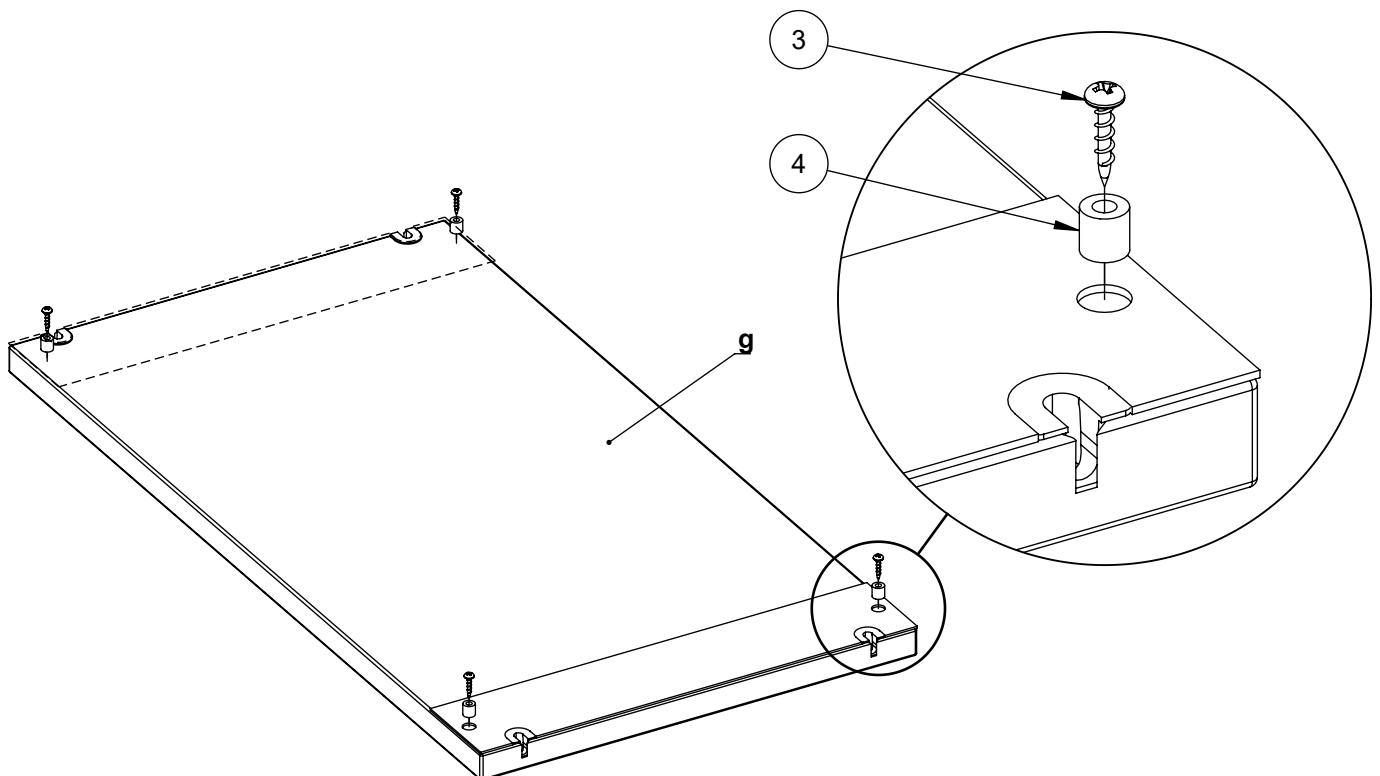
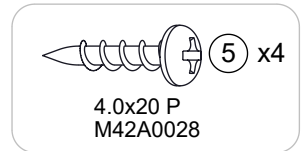
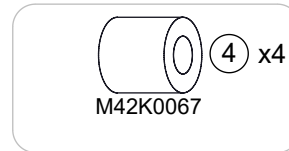

**b.6** Remove the template  
Vorlage entfernen  
Retirer le modèle

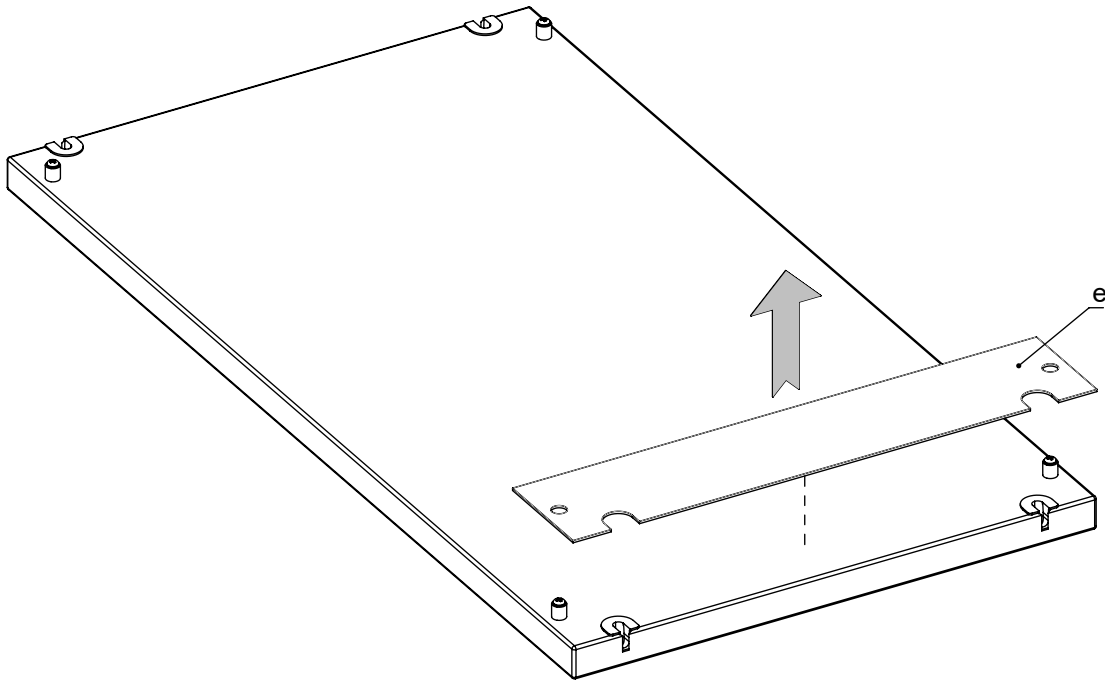



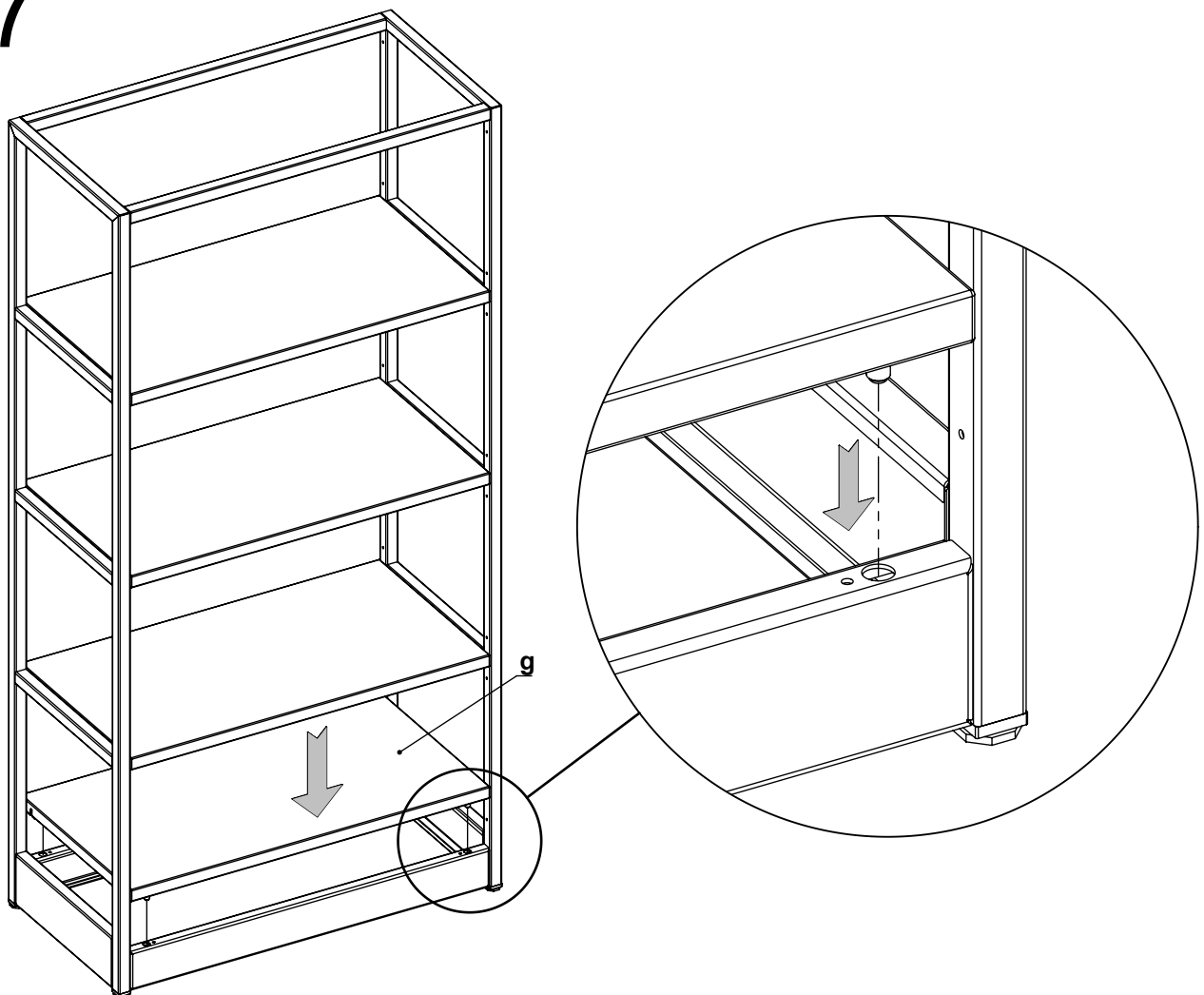



**b.7**



# COMBUS

EN Assembly scheme | DE Aufbauanleitung | FR Schéma d'assemblage

 <b>00:20*</b>	 <b>x2</b>	   
--	---	---

instructions.narbutas.com

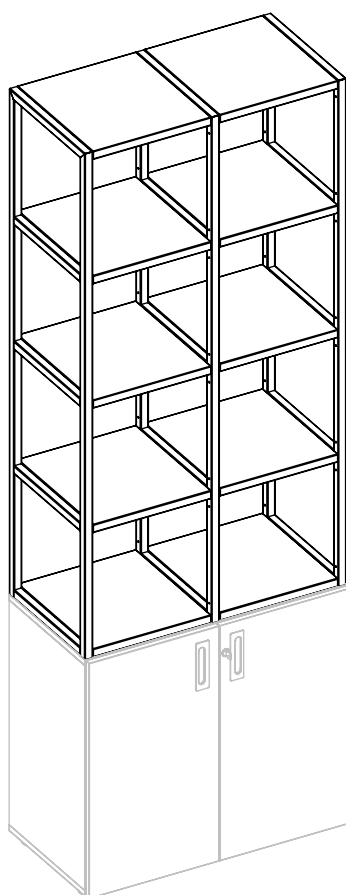

Example of the combination. Specific combination (wide, height, storage components type) depends on order option and chosen accessories.

\*Indicative assembly time of single 4H module combination with shelves.

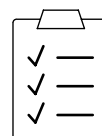

Beispiel für eine Kombination. Die konkrete Kombination (Breite, Höhe, Art der Ablagen) hängt von der Wahl der Komponenten und den Bestelloptionen ab.

\*Etwaige Montagedauer eines einzelnen 4H Segments mit Regalböden.

Exemple de combinaison. La combinaison spécifique (largeur, hauteur, type d'éléments de rangement) dépend de l'option de commande et des éléments choisis.

\*Durée de montage indicative d'un segment 4H avec étagères.

Modules size  
 Modulgröße  
 Taille des modules.

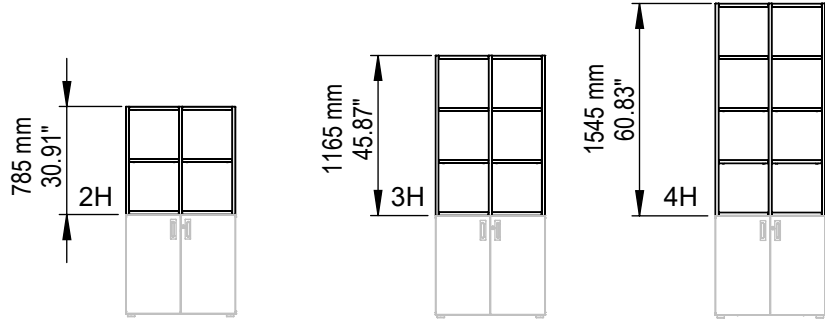

\* Set of storage components depends on order option and chosen accessories. This instructions document contains assembly information for storage elements with shelves. Instructions for other options provided with other packages.

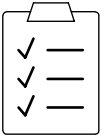

Das Set der Ablagen hängt von den Bestelloptionen und dem gewählten Zubehör ab. Diese Anleitung enthält Montageinformationen für Segmente mit Regalböden. Die Anleitungen für andere Optionen liegen den jeweiligen Packungen bei.

Le jeu d'éléments de rangement dépend de l'option de commande et des accessoires choisis. Ce document d'instructions contient des informations sur l'assemblage des segments de rangement avec étagères. Les instructions pour les autres options sont fournies dans leur emballage.

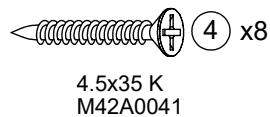
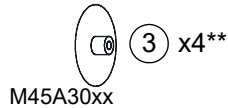
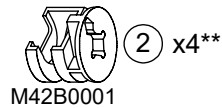
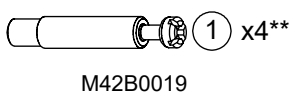
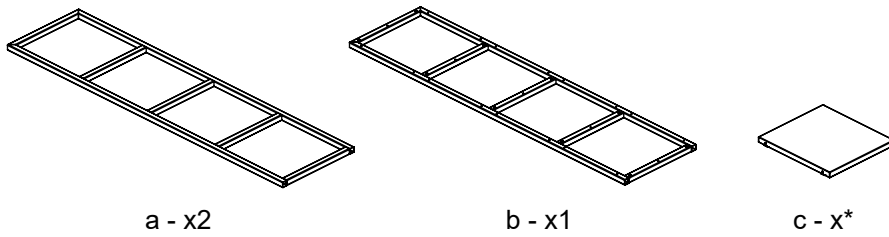
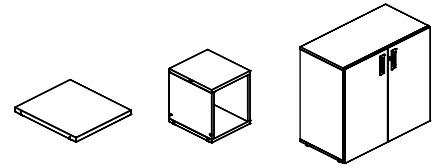

\*\*  
 4 pcs/shelve  
 4 Stück/Regal  
 4 pièces/étagère

# Stability requirements

It is always recommended to fix COMBUS storage system the wall, considering there is a tip over risk.

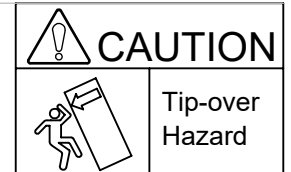

Compulsory measures to ensure furniture stability:

Overall height	Compulsory measure
≤ 5H	-
6H	It is mandatory to fix combination to the wall!
> 6H	Combination is not allowed!

# Stabilitätsanforderungen

Es wird empfohlen, eine Kombinationen immer an Wand zu befestigen, weil sonst das Risiko des Umfallens besteht.



Obligatorische Maßnahmen für die Stabilität des Möbelstücks:

Gesamthöhe	Obligatorische Maßnahmen
≤ 5H	-
6H	Befestigen Sie bitte die Kombination an der Wand!
> 6H	Diese Kombination ist nicht verfügbar!

# Exigences de stabilité

Il est toujours recommandé de fixer la combinaison au mur, compte tenu d'un risque de basculement.



Mesures obligatoires pour assurer la stabilité du mobilier :

Hauteur totale	Mesures obligatoires
≤ 5H	-
6H	Veillez fixer votre combinaison au mur !
> 6H	Combinaison non disponible !

Example  
das Exempel  
l' exemple

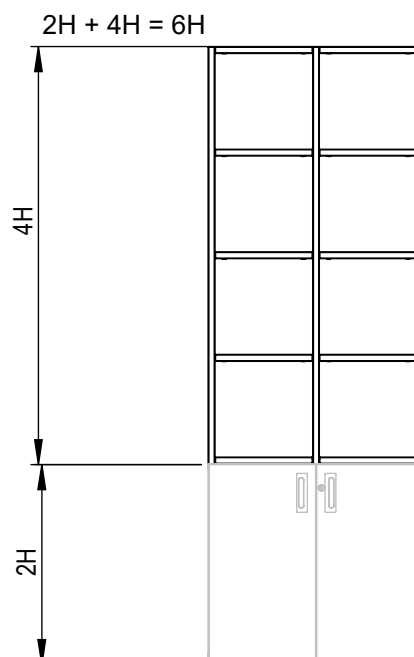

# 1

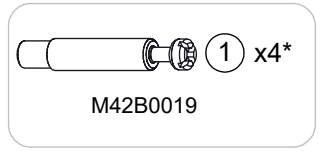
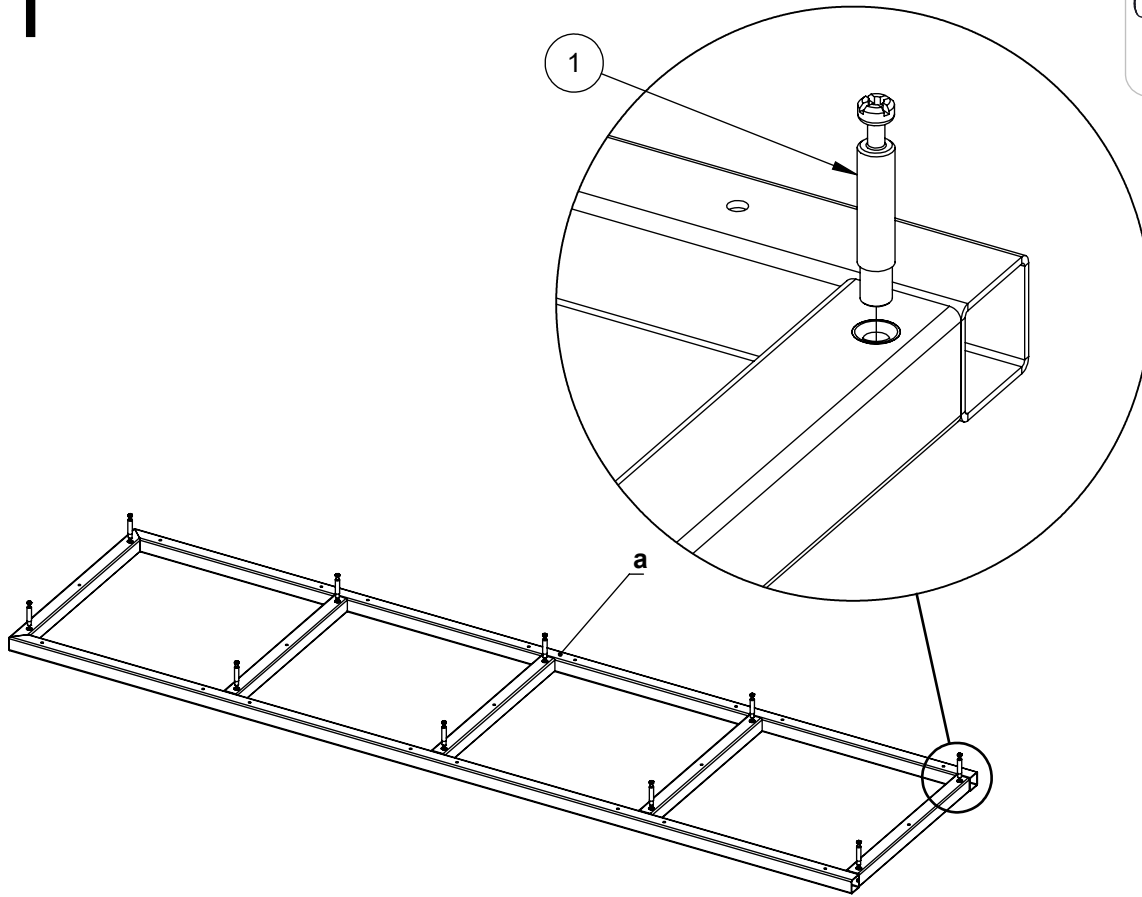

M42B0019  
\* 4 pcs/shelve  
4 Stück/Regal  
4 pièces/étagère

# 2

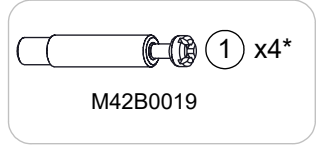
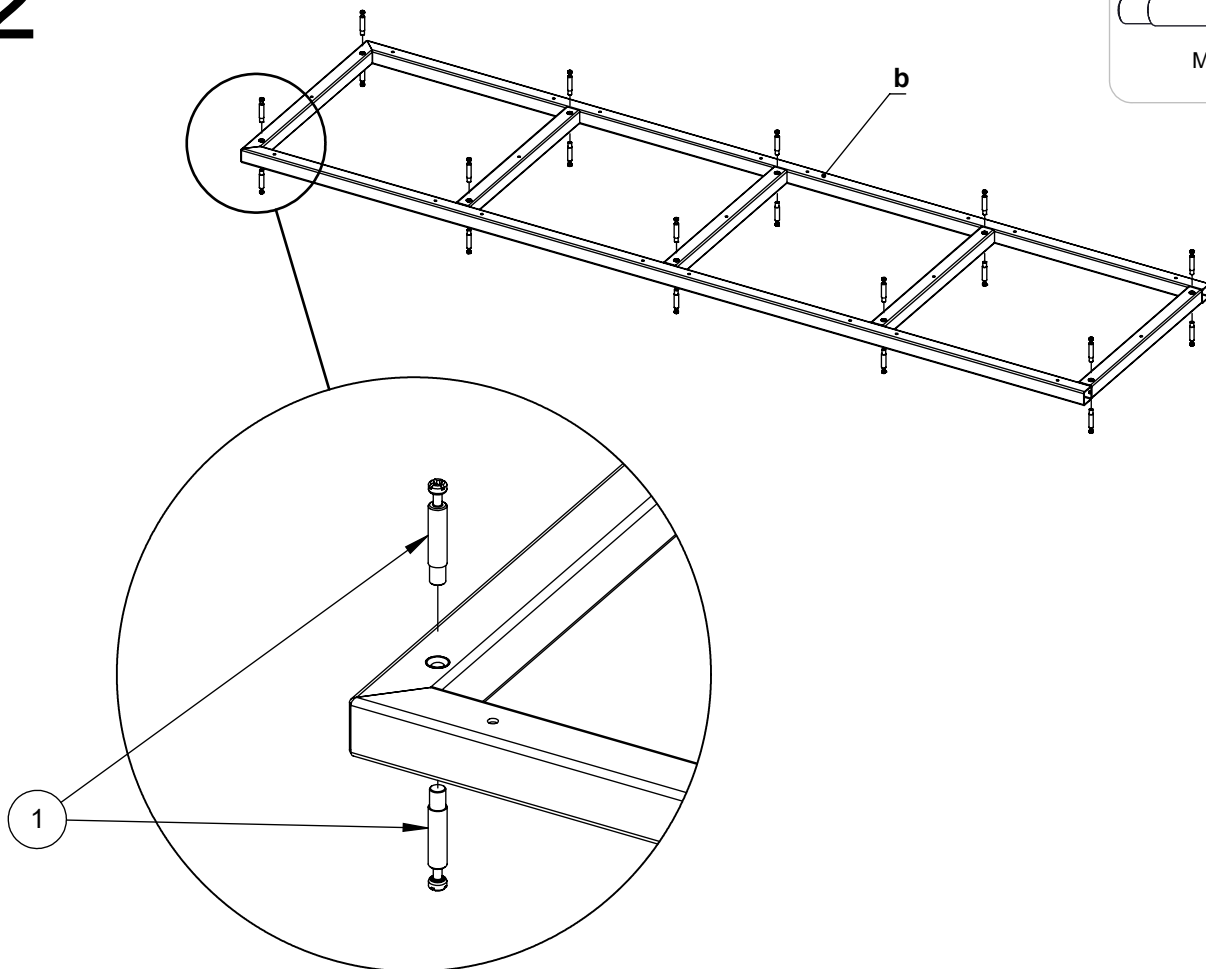

M42B0019  
\* 4 pcs/shelve  
4 Stück/Regal  
4 pièces/étagère



**i** Set of storage components depends on order option and chosen accessories. This instructions document contains assembly information for storage elements with shelves. Instructions for other options provided with other packages.

Das Set der Ablagen hängt von den Bestelloptionen und dem gewählten Zubehör ab. Diese Anleitung enthält Montageinformationen für Segmente mit Regalböden. Die Anleitungen für andere Optionen liegen den jeweiligen Packungen bei.

Le jeu d'éléments de rangement dépend de l'option de commande et des accessoires choisis. Ce document d'instructions contient des informations sur l'assemblage des segments de rangement avec étagères. Les instructions pour les autres options sont fournies dans leur emballage.

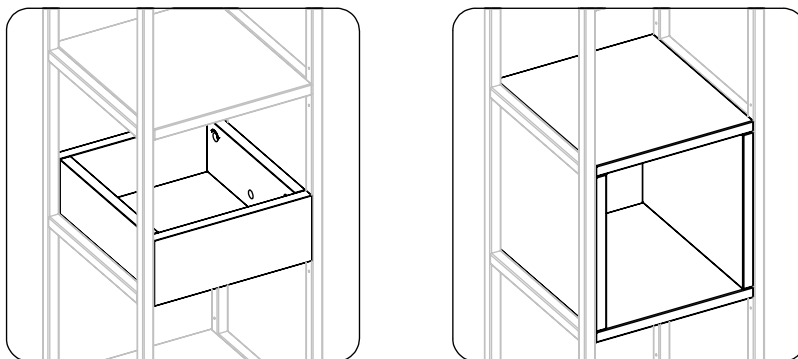

**3**

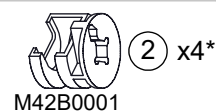
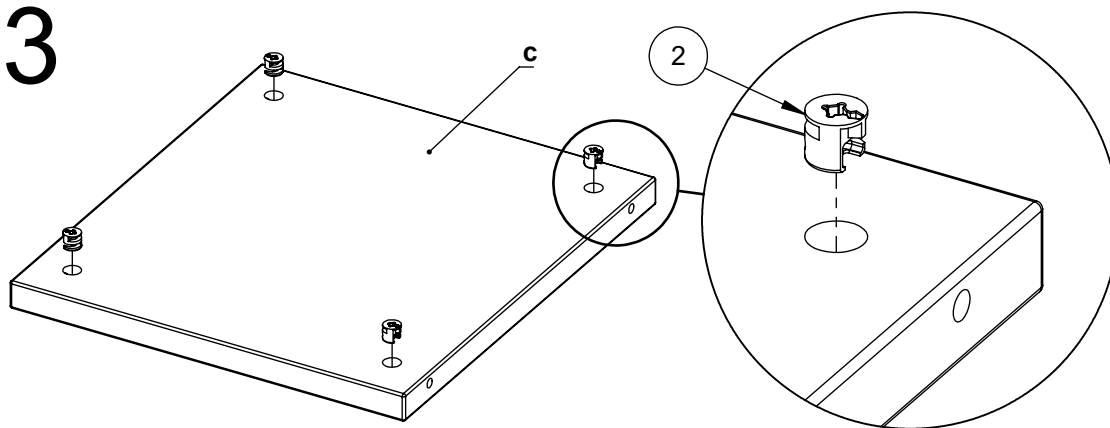

\* 4 pcs/shelve  
4 Stück/Regal  
4 pièces/étagère

**4**

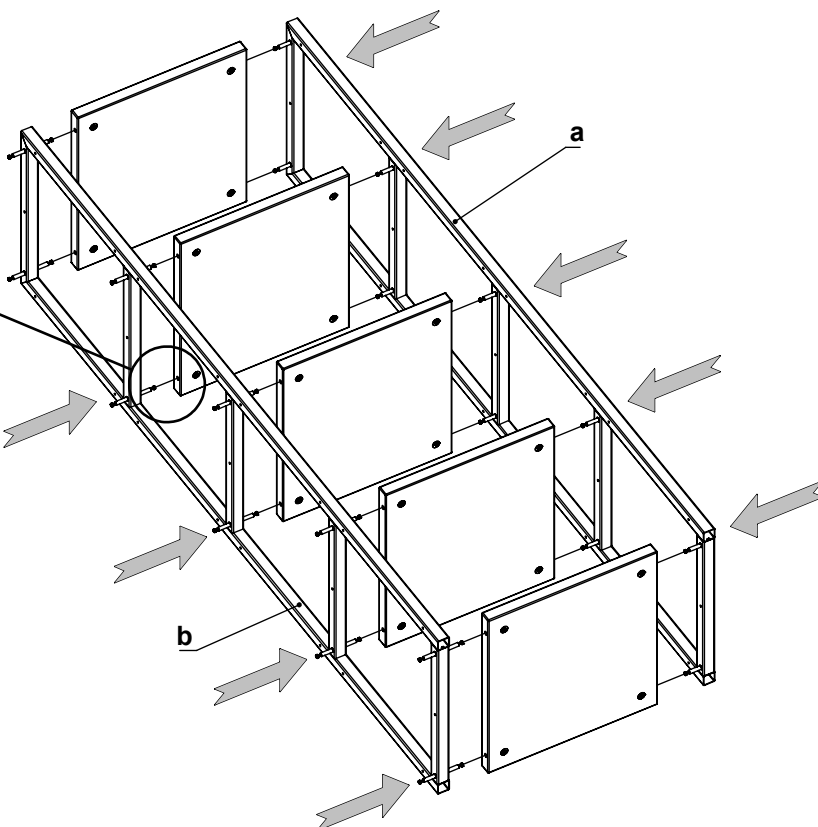
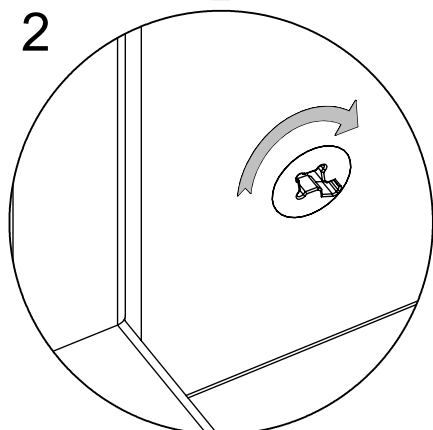
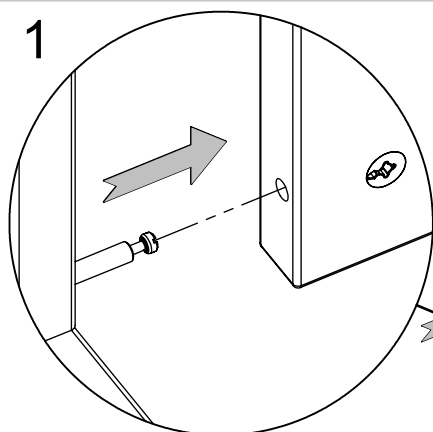

# 5

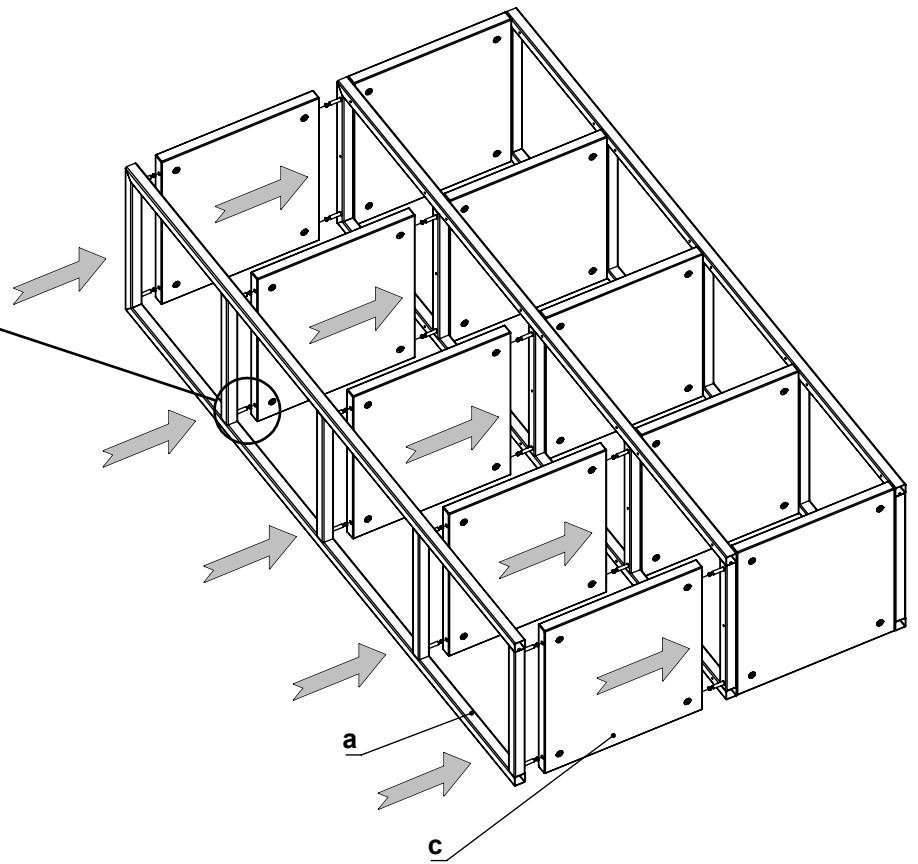
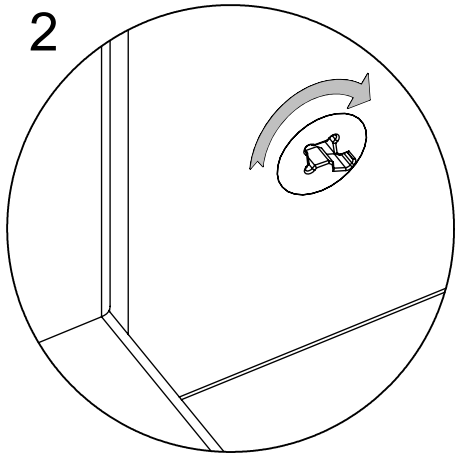
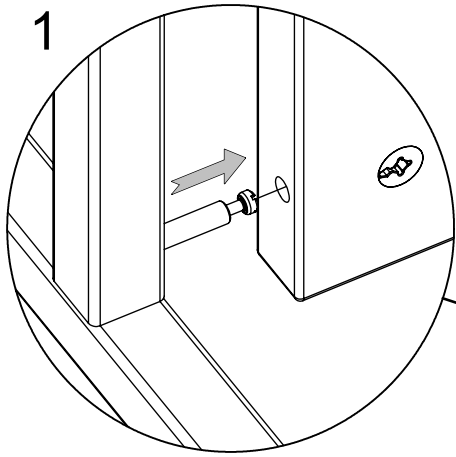

# 6

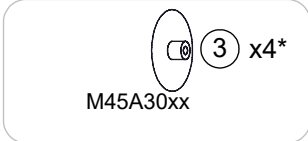
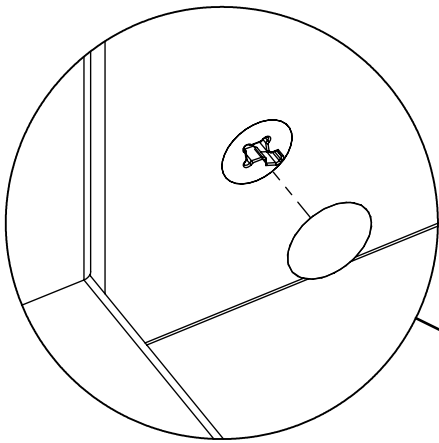

\* 4 pcs/shelve  
4 Stück/Regal  
4 pièces/étagère

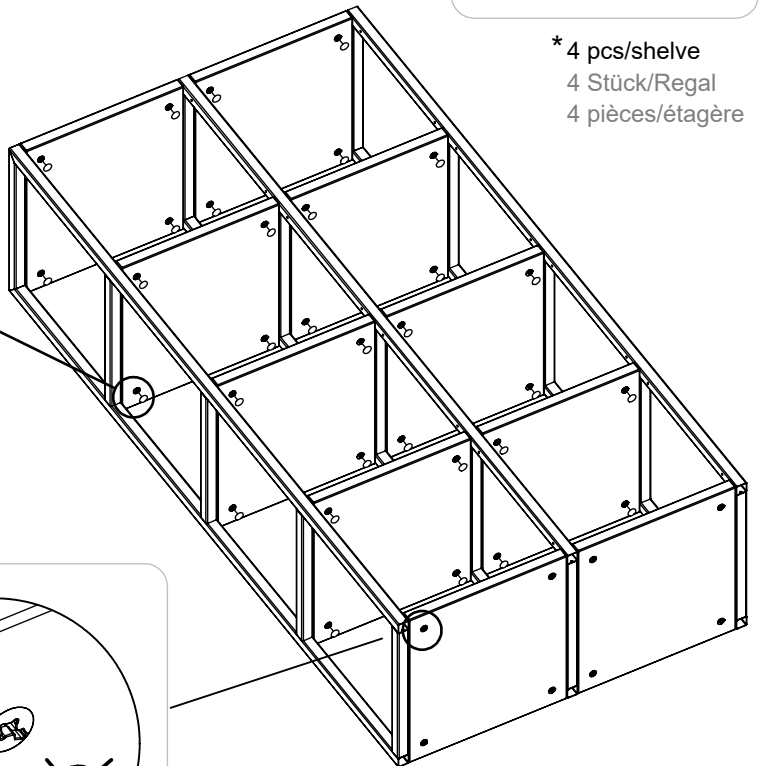

Do not install caps to the bottom shelves.

Die Verbindungsstücke nicht in jeder Position montiert werden.

Raccords ne doivent pas être installés à chaque position.

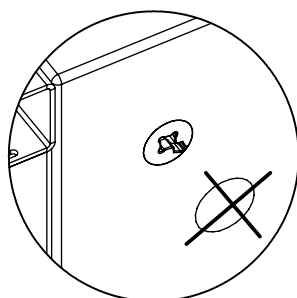

7

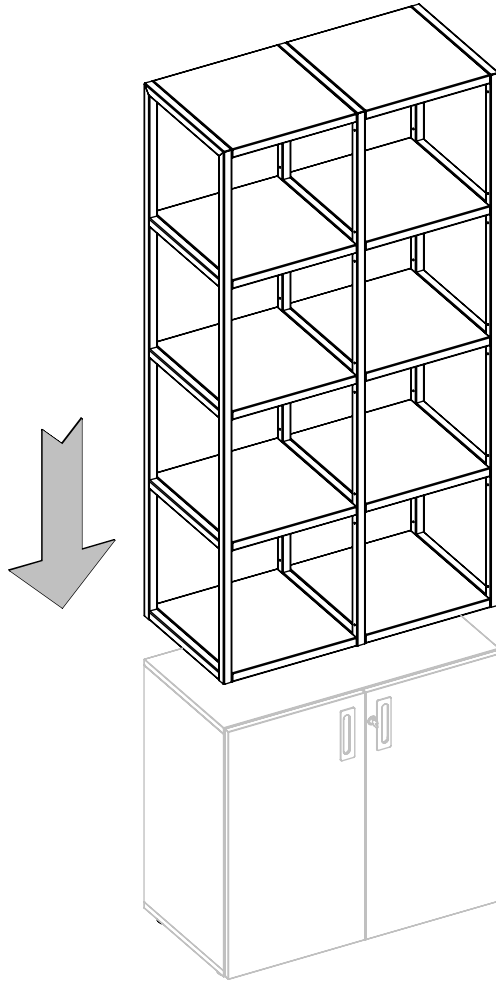

8

Align the units  
Einheiten ausrichten  
Aligner les unités

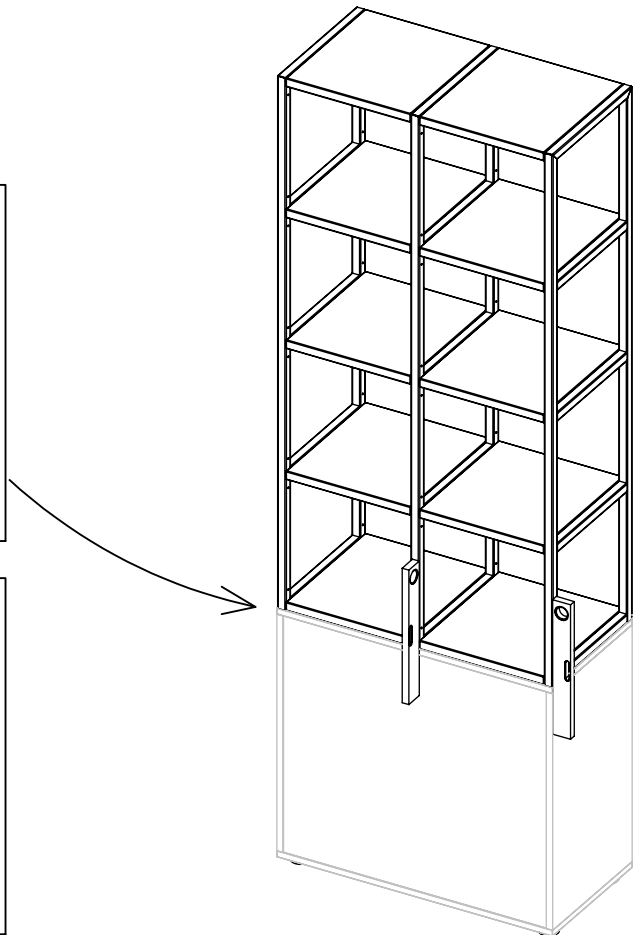
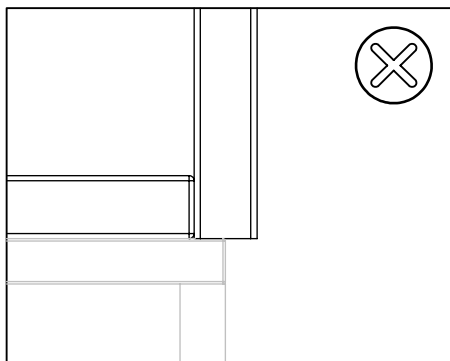

# 9



4.5x35 K  
M42A0041

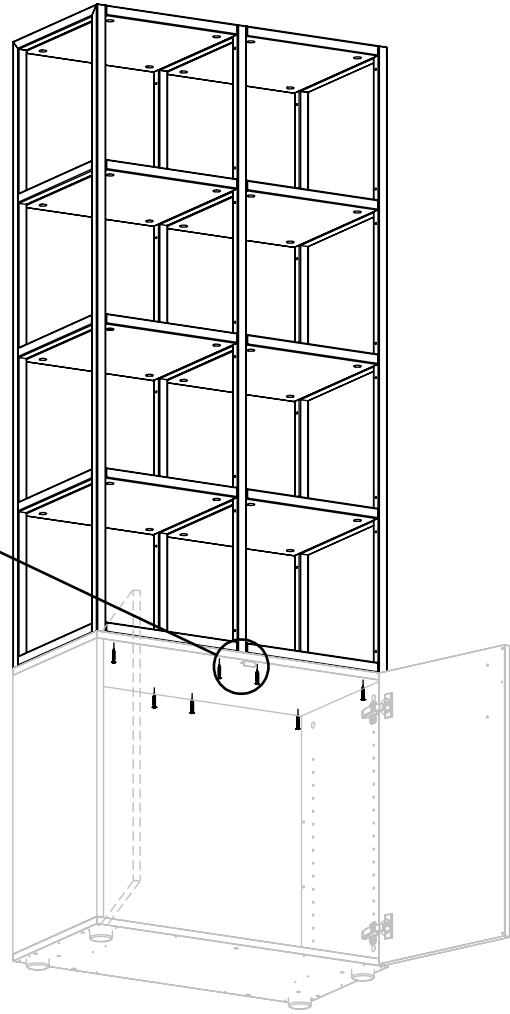
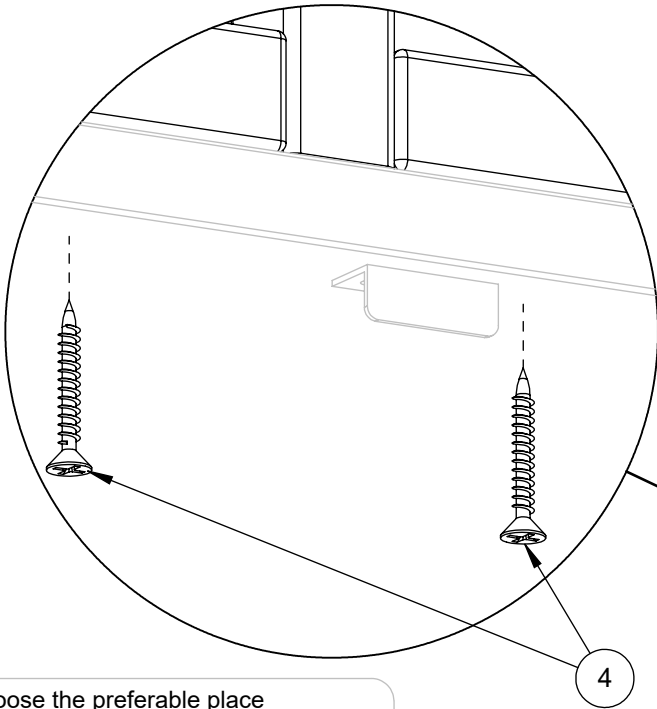



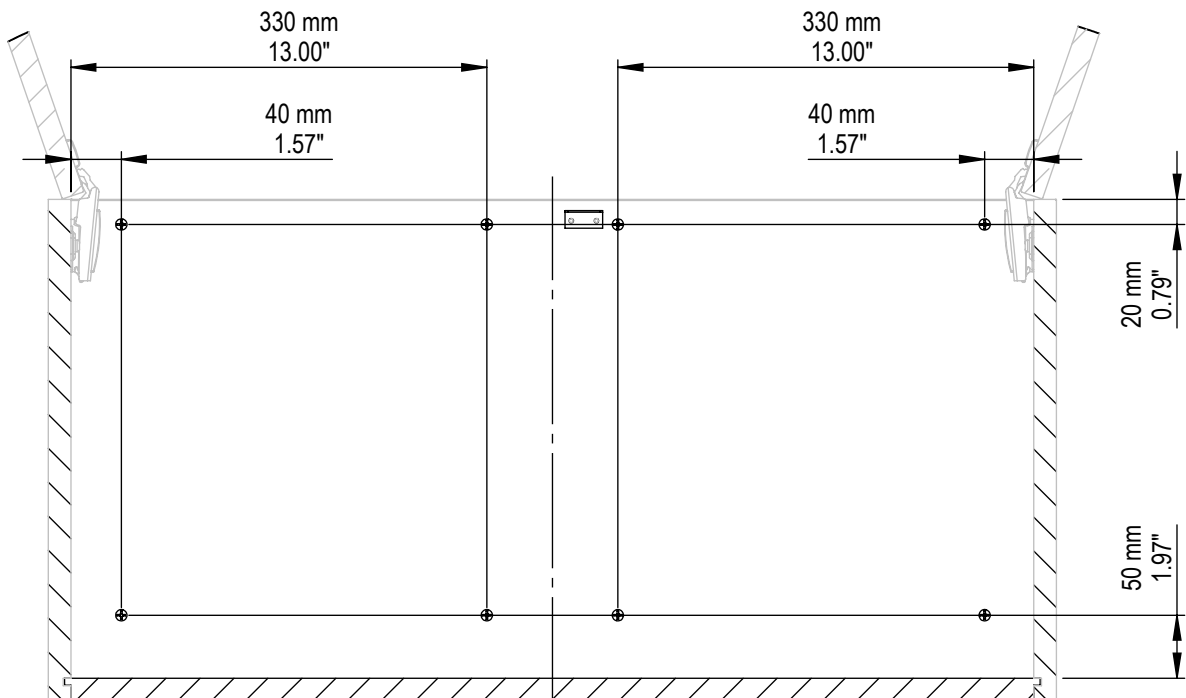

Choose the preferable place  
Den gewünschten Aufstellort auswählen  
Choisir l'endroit approprié

Recommended fixing places  
Empfohlene Befestigungsorte  
Emplacements de fixation recommandés



# COMBUS

EN Assembly scheme | DE Aufbauanleitung | FR Schéma d'assemblage

 <b>00:15</b>	 <b>x1</b>	 
---	---	---

instructions.narbutas.com

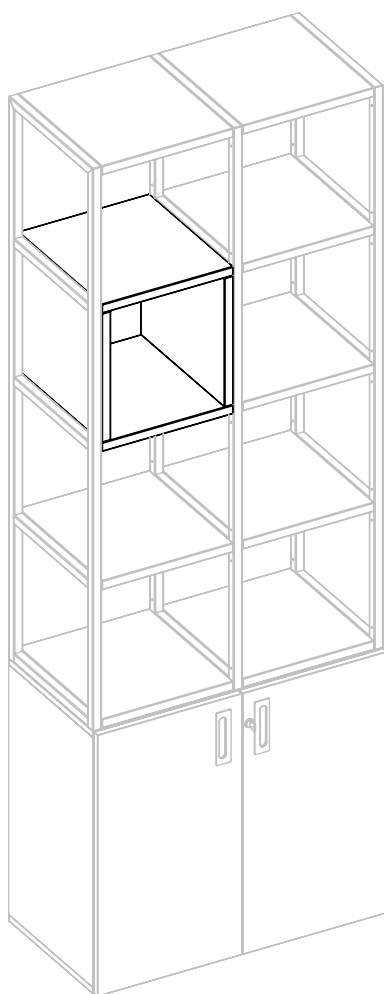

Example of the combination. Specific combination (wide, height, storage components type) depends on order option and chosen components.

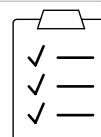

Beispiel für eine Kombination. Die konkrete Kombination (Breite, Höhe, Art der Ablagen) hängt von der Wahl der Komponenten und den Bestelloptionen ab.

Exemple de combinaison. La combinaison spécifique (largeur, hauteur, type d'éléments de rangement) dépend de l'option de commande et des éléments choisis.

- Set of storage components depends on order option and chosen accessories. Instructions for other options provided with other packages.
- Sets can be chosen individually and placed in various positions upon assembly.
- Open/closed shelf boxes and a cabinet with a drawer cannot be mounted on the top of each other.
- Back panels cannot be mounted on the back of the open shelf box.

- Das Set der Ablagen hängt von den Bestelloptionen und dem gewählten Zubehör ab. Die Anleitungen für andere Optionen liegen den jeweiligen Packungen bei.
- Die Sets können individuell ausgewählt und bei der Montage in verschiedenen Positionen platziert werden.
- Die offenen und geschlossenen Regalboxen und der Schrank mit Schubfach können nicht übereinander montiert werden.
- Auf der Rückseite der offenen Regalbox kann keine Rückwand montiert werden.

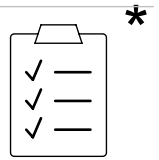

- Le jeu d'éléments de rangement dépend de l'option de commande et des accessoires choisis. Les instructions pour les autres options sont fournies dans leur emballage.
- Les jeux peuvent être choisis individuellement et placés dans différentes positions lors de l'assemblage.
- Les caissons d'étagère ouverts/fermés et les armoires à tiroirs ne peuvent pas être montés l'un sur l'autre.
- Les panneaux arrière ne peuvent pas être montés à l'arrière de l'étagère ouverte.

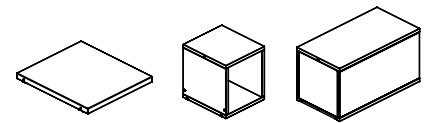

### Units sizes

Größe der Einheit

Taille de l'unité

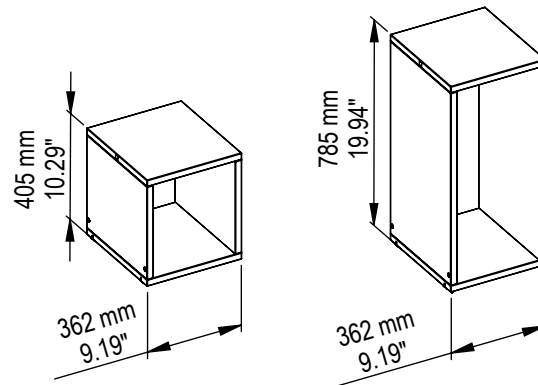

**a**

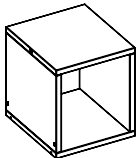

G1B417

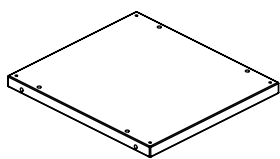

a - x1

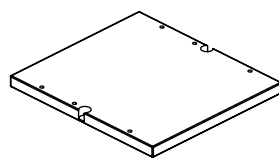

b - x1

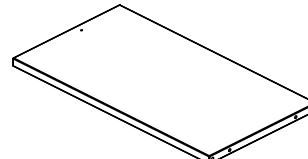

c - x1

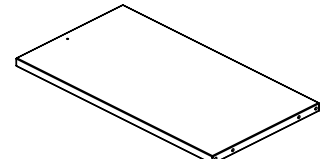

d - x1

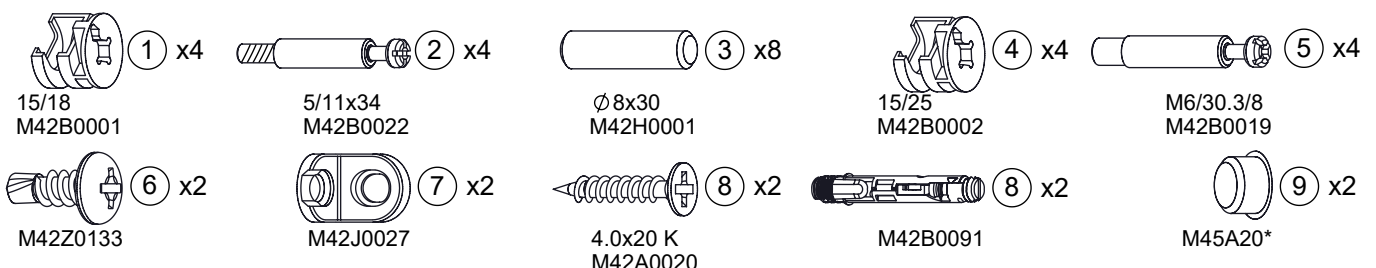

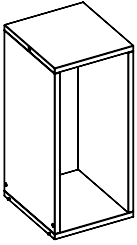
**b**

G1B346

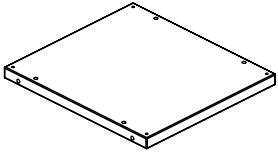

a - x1

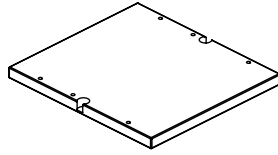

b - x1

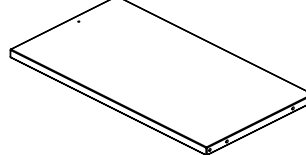

c - x1

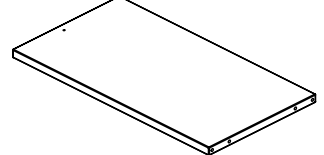

d - x1

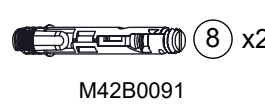
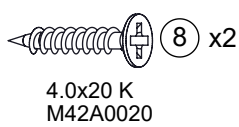
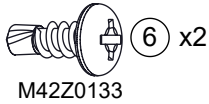
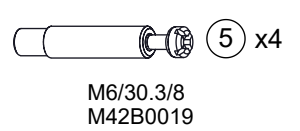
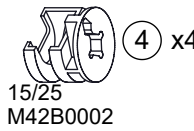
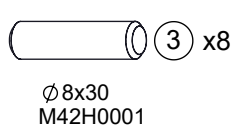
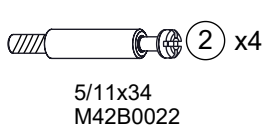
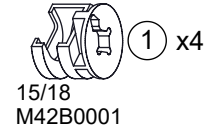
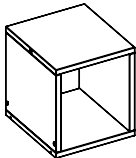
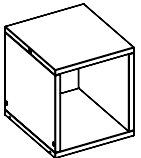
**C**

G1B451

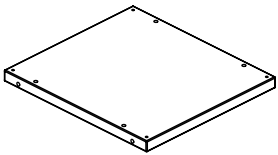

a - x2

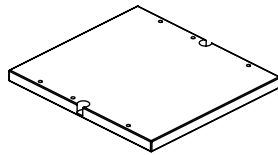

b - x2

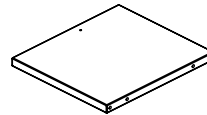

c - x2

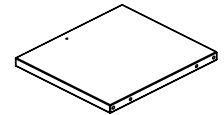

d - x2

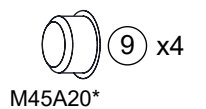
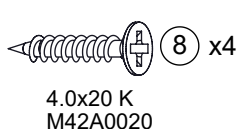
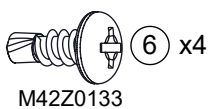
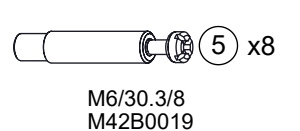
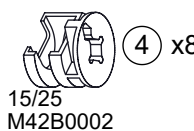
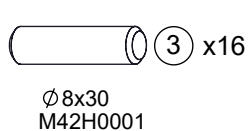
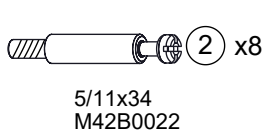
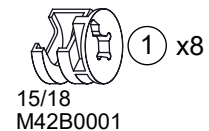

d

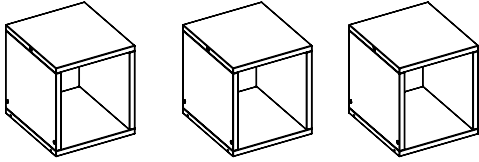

G1B379

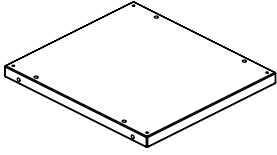

a - x3

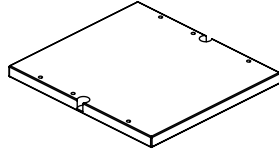

b - x3

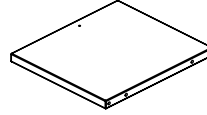

c - x3

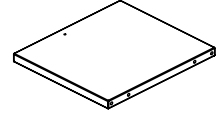

d - x3



15/18  
M42B0001

① x12

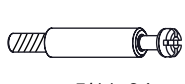

5/11x34  
M42B0022

② x12



∅8x30  
M42H0001

③ x24



15/25  
M42B0002

④ x12



M6/30.3/8  
M42B0019

⑤ x12

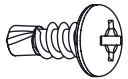

M42Z0133

⑥ x6

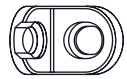

M42J0027

⑦ x6



4.0x20 K  
M42A0020

⑧ x6

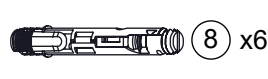

M42B0091

⑧ x6

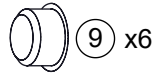

M45A20\*

⑨ x6



# 1

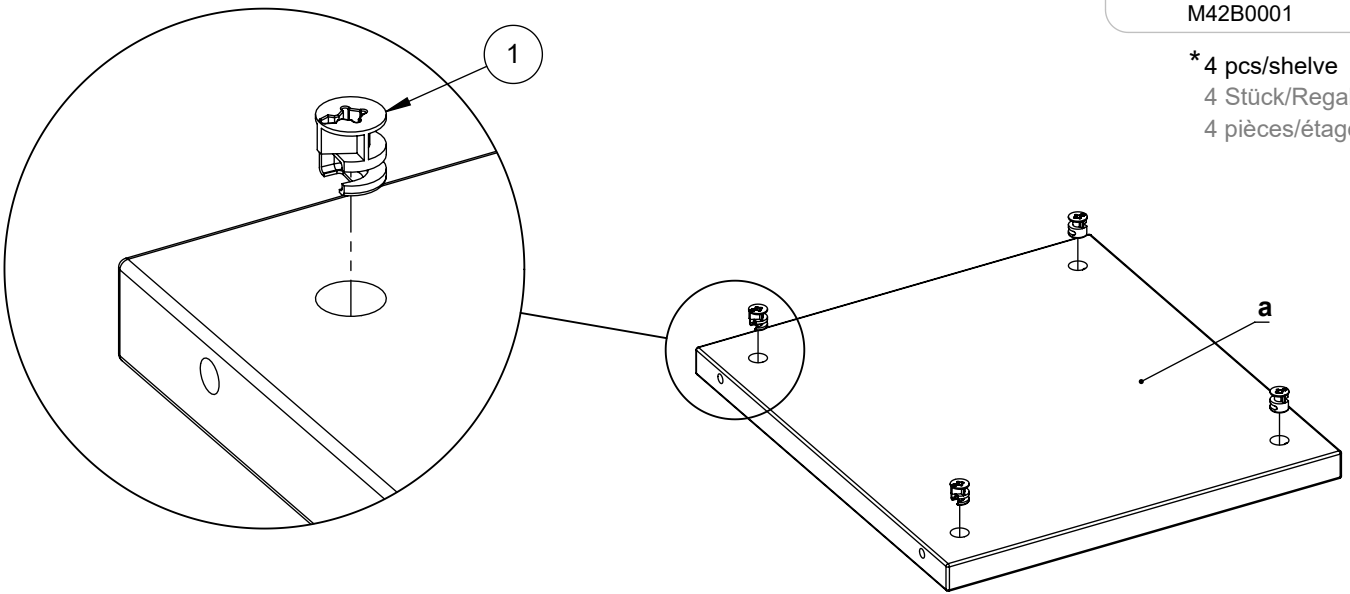

1 x4\*  
15/18  
M42B0001

\* 4 pcs/shelve  
4 Stück/Regal  
4 pièces/étagère

# 2

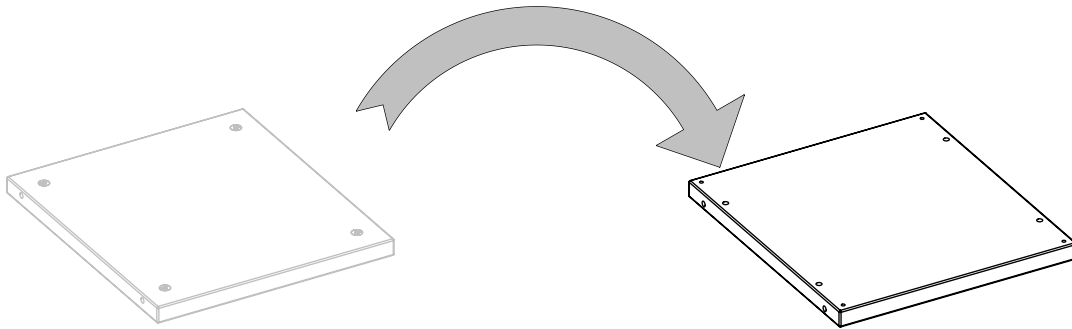

# 3



2 x4\*  
5/11x34  
M42B0022



3 x4\*  
Ø8x30  
M42H0001

\* 4 pcs/shelve  
4 Stück/Regal  
4 pièces/étagère

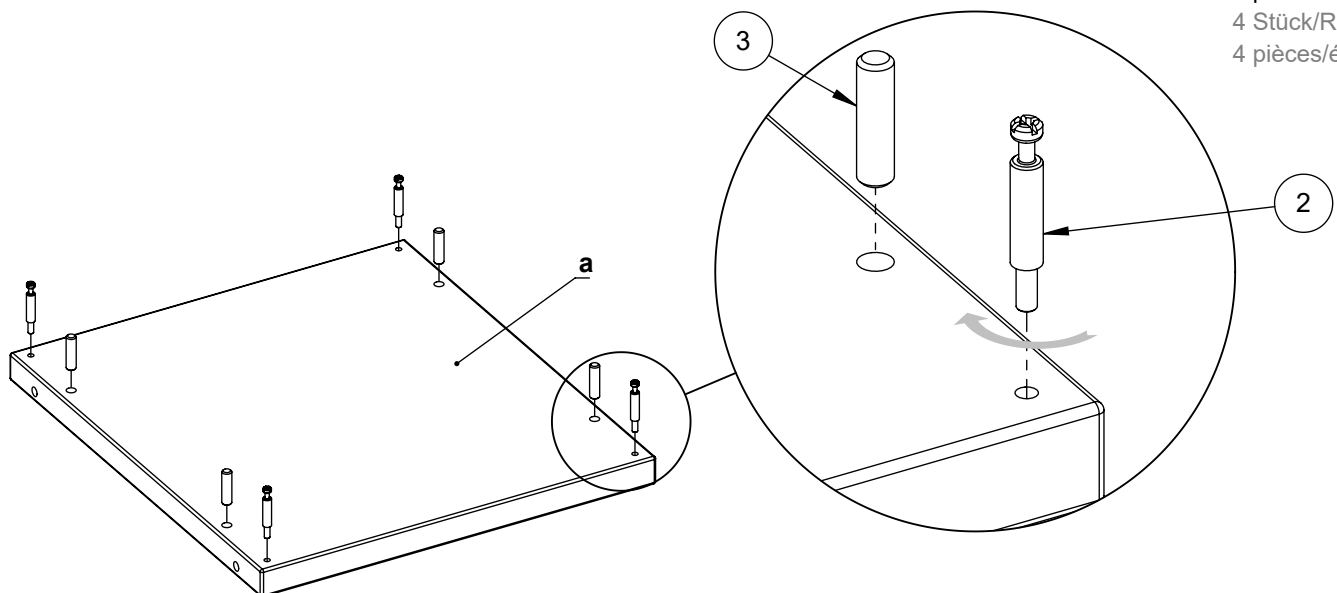

# 4

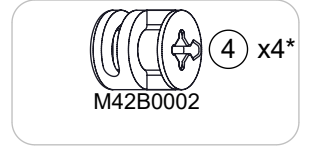

\* 4 pcs/shelve  
4 Stück/Regal  
4 pièces/étagère

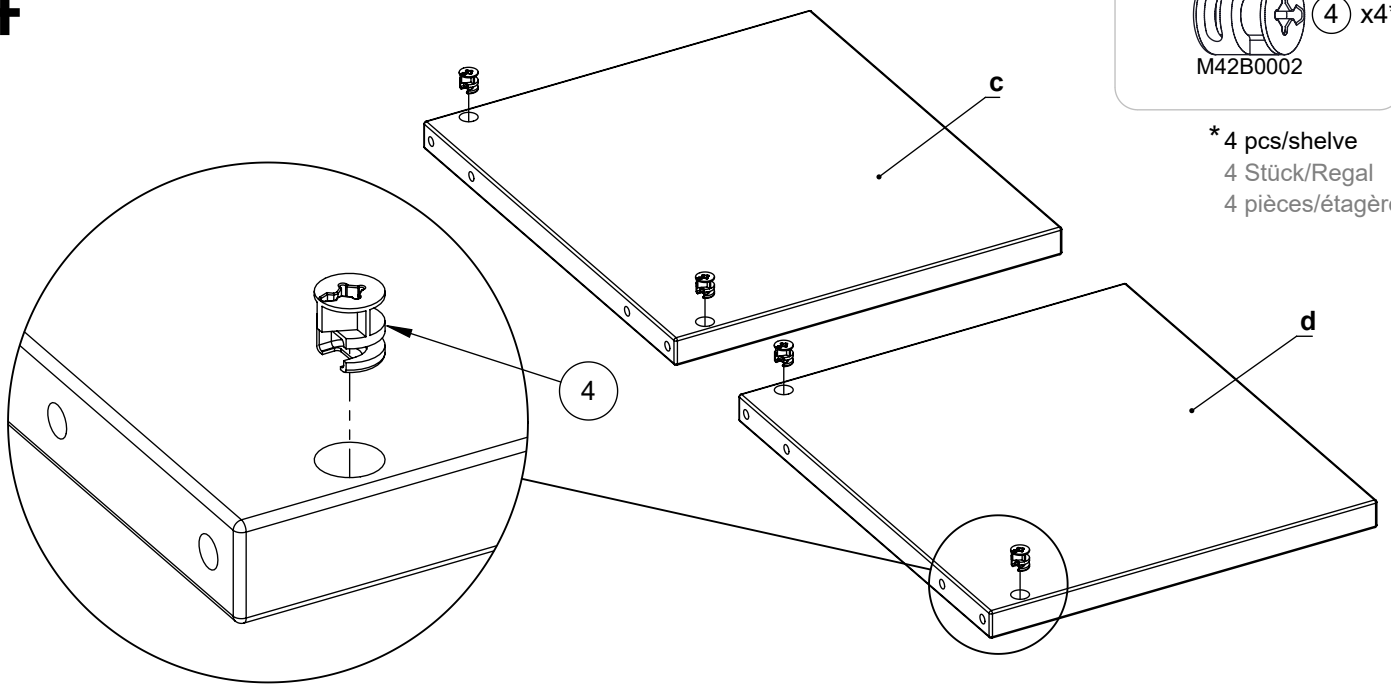

# 5

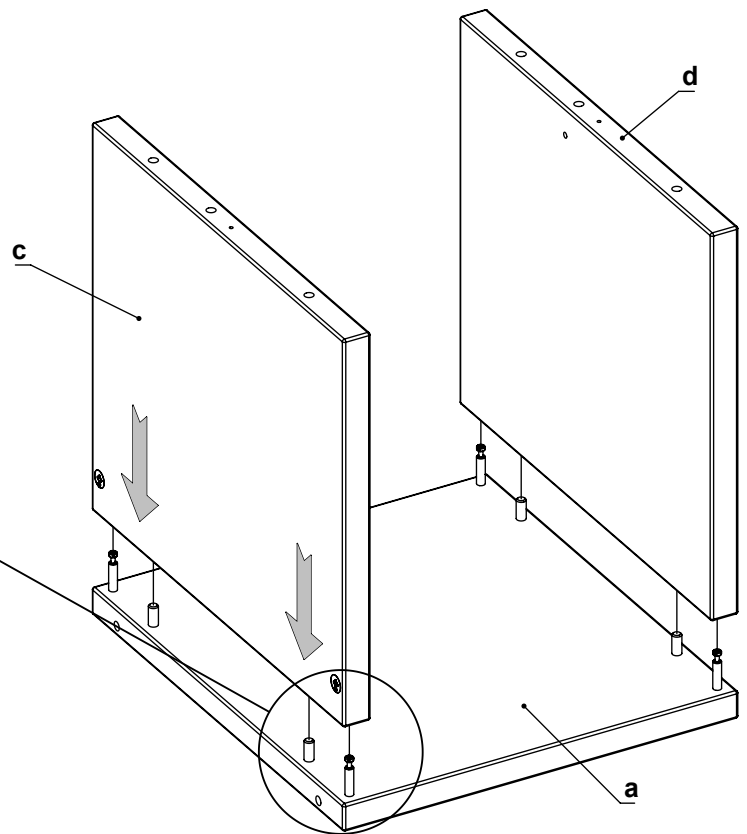
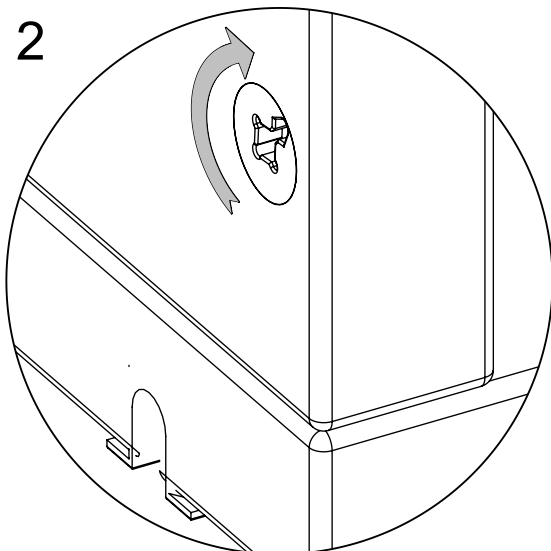
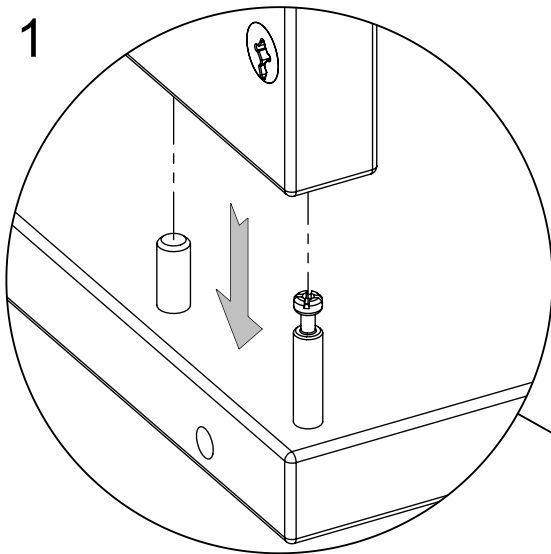

**i**

Instructions for other storage components provided with their packaging.

Die Anleitungen für andere optionale Komponenten liegen den jeweiligen Packungen bei.

Les instructions pour les autres éléments de rangement sont fournies dans leur emballage.

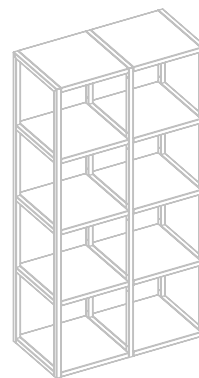

**M60EJ036**

**6**

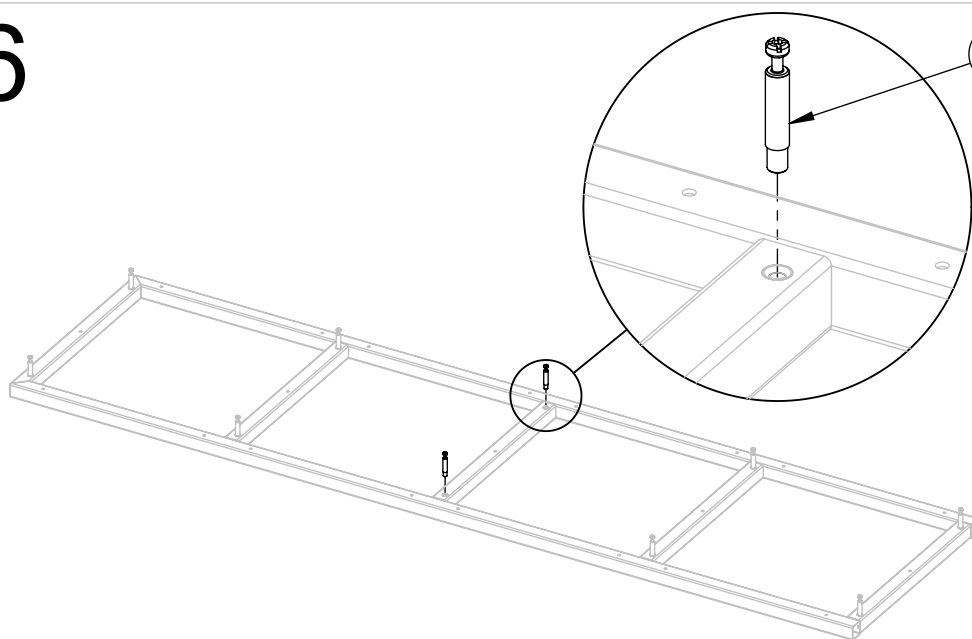

5

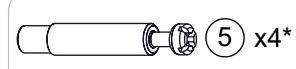

M6/30.3/8  
M42B0019

\* 4 pcs/shelve  
4 Stück/Regal  
4 pièces/étagère

**7**

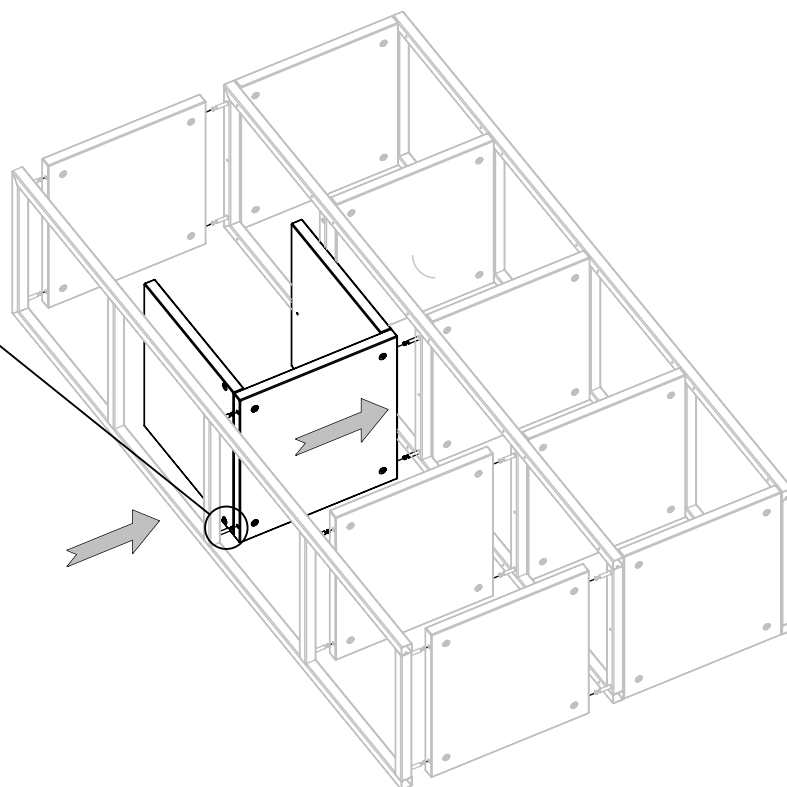
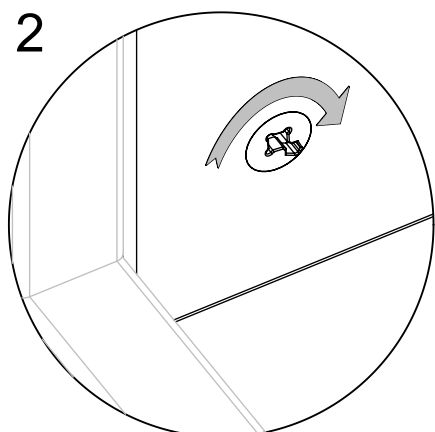
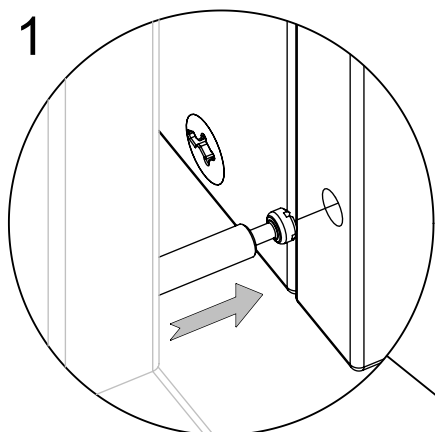

# 8

Check the alignment  
Überprüfen Sie die Ausrichtung  
Vérifier l'alignement

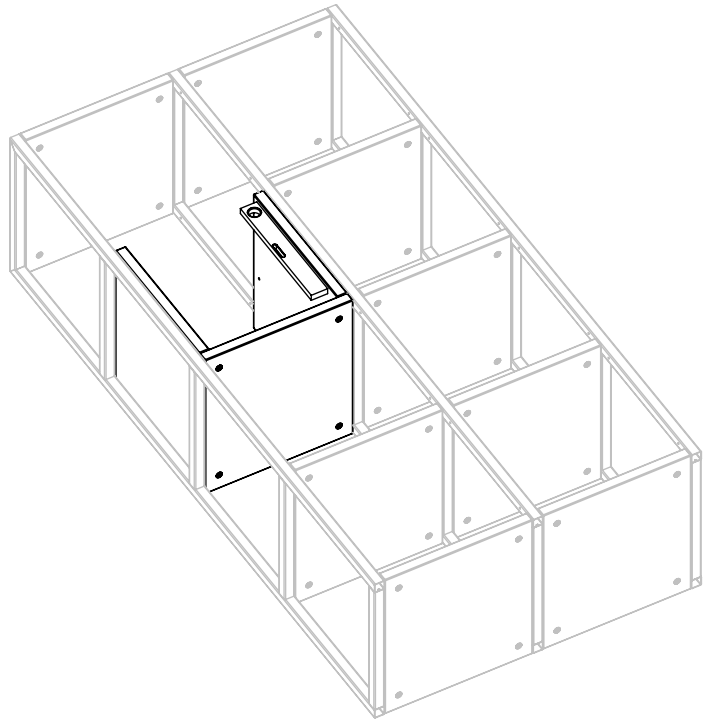
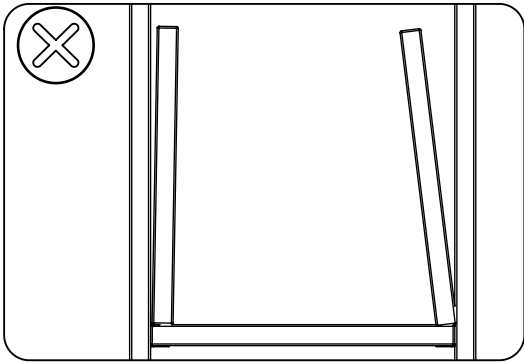
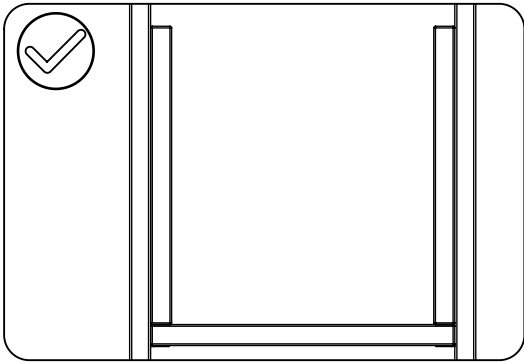
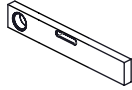

# 9

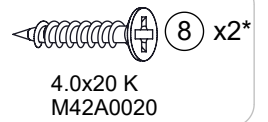
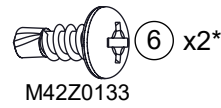
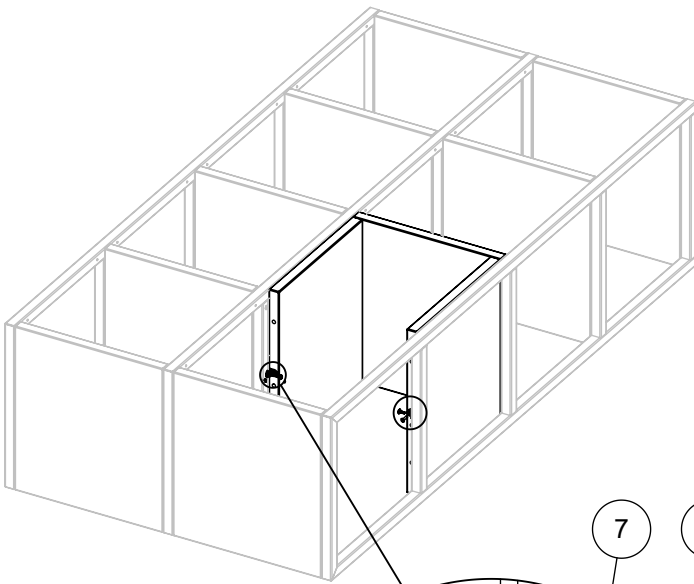

\* 2 pcs/shelve  
2 Stück/Regal  
2 pièces/étagère

1

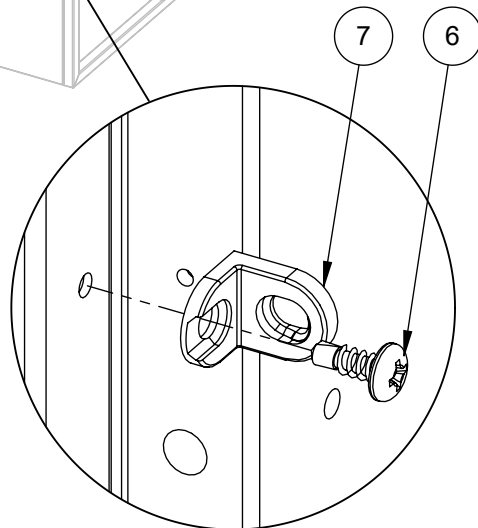

2

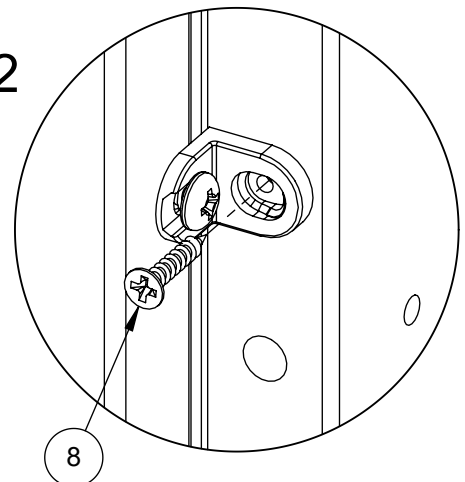

# 10

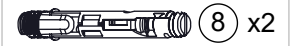
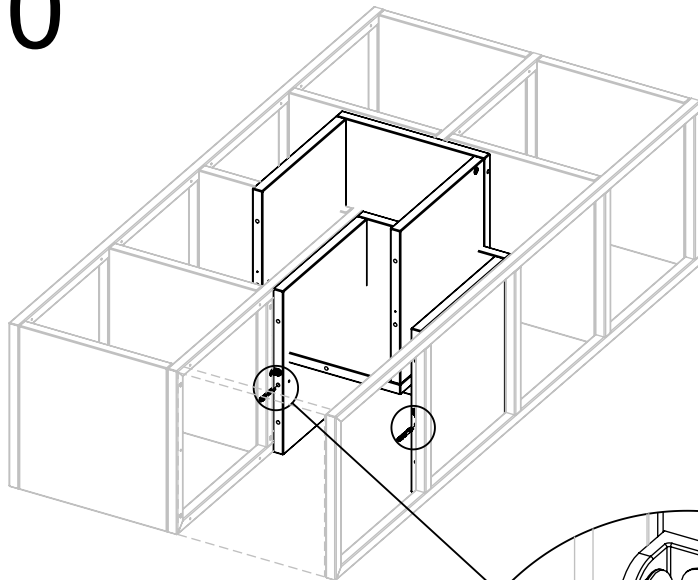

M42B0091

\* 2 pcs/shelve  
2 Stück/Regal  
2 pièces/étagère

Align (8) pin with the hole  
Pin (8) mit dem Loch ausrichten  
Aligner la broche (8) ave le trou

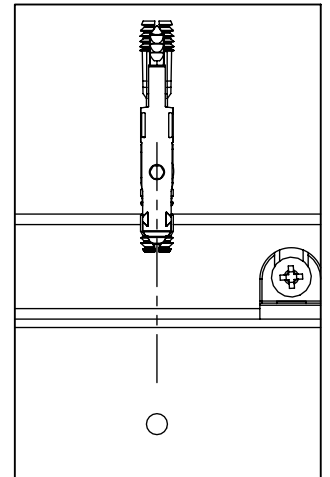
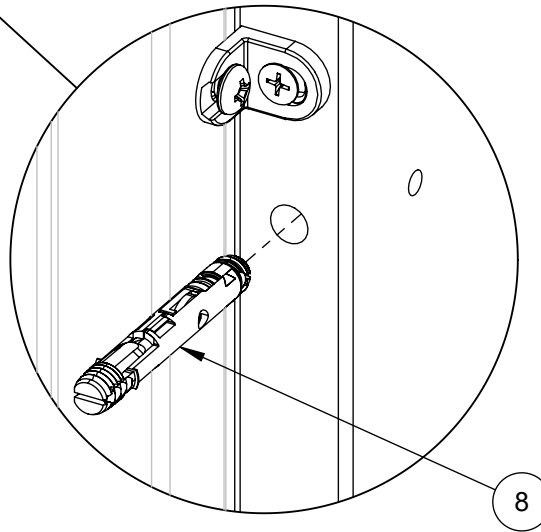

# 11



Ø8x30  
M42H0001

\* 4 pcs/shelve  
4 Stück/Regal  
4 pièces/étagère

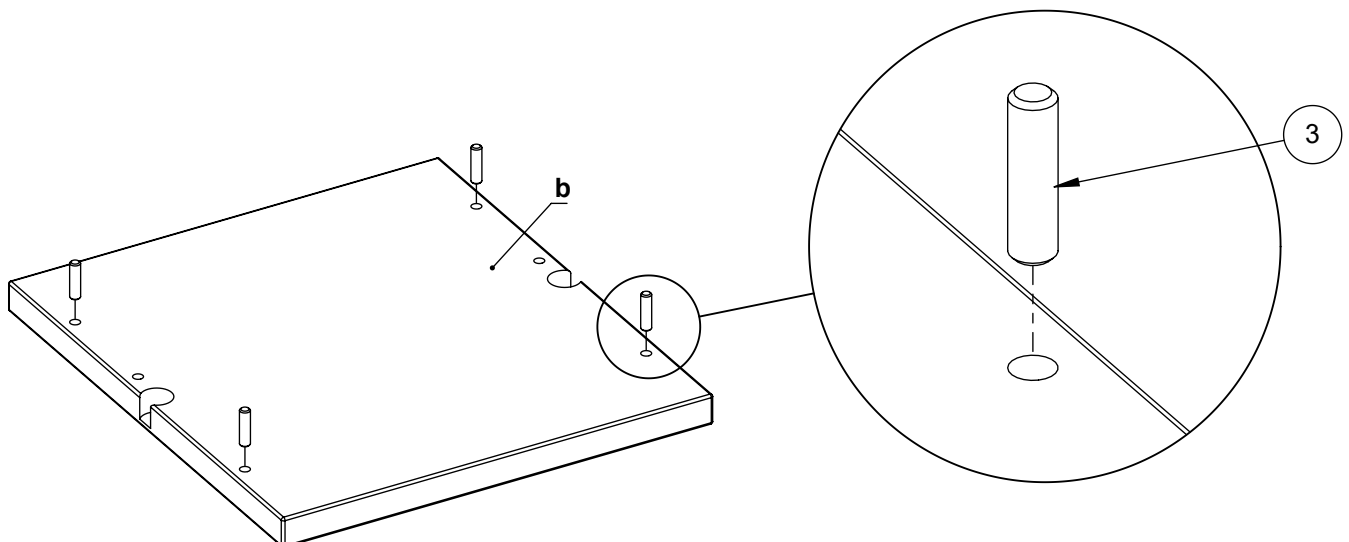

# 12

Place the top  
Oberseite aufsetzen  
Placer la partie supérieure

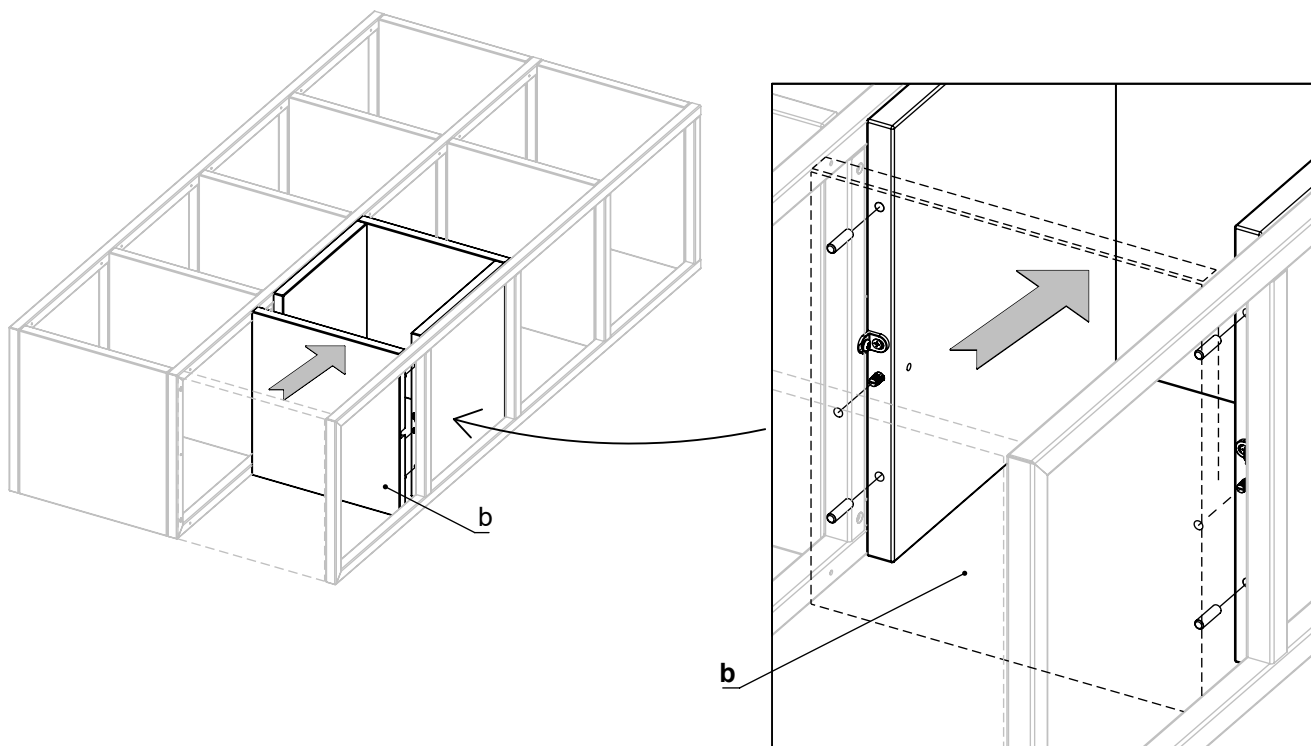

# 13

Do not overtighten  
Nicht überdrehen  
Ne serrez pas trop les vis



 9 x2  
M45A20\*

1

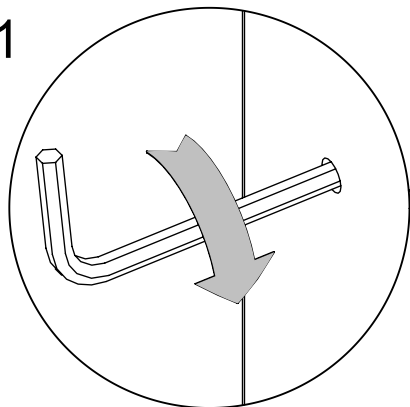

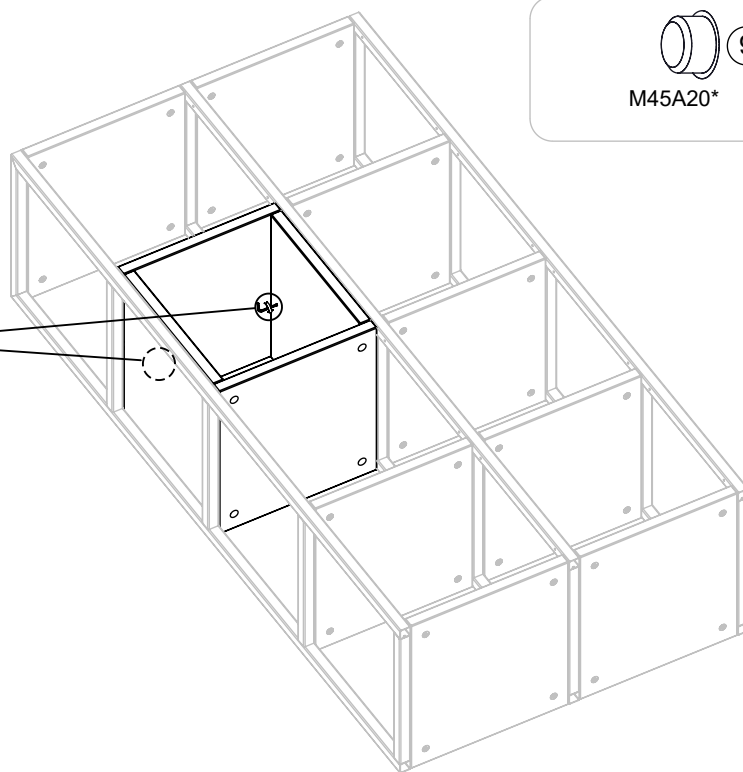
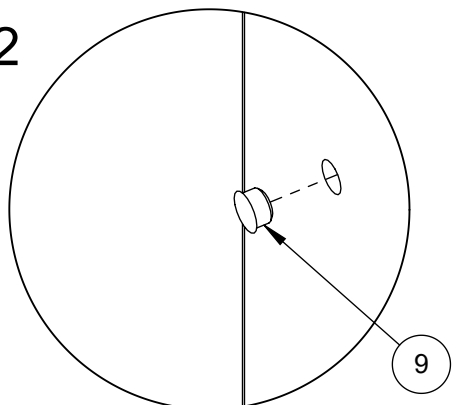

2



# COMBUS

EN Assembly scheme | DE Aufbauanleitung | FR Schéma d'assemblage

 00:05	 x1	
--	--	--

instructions.narbutas.com

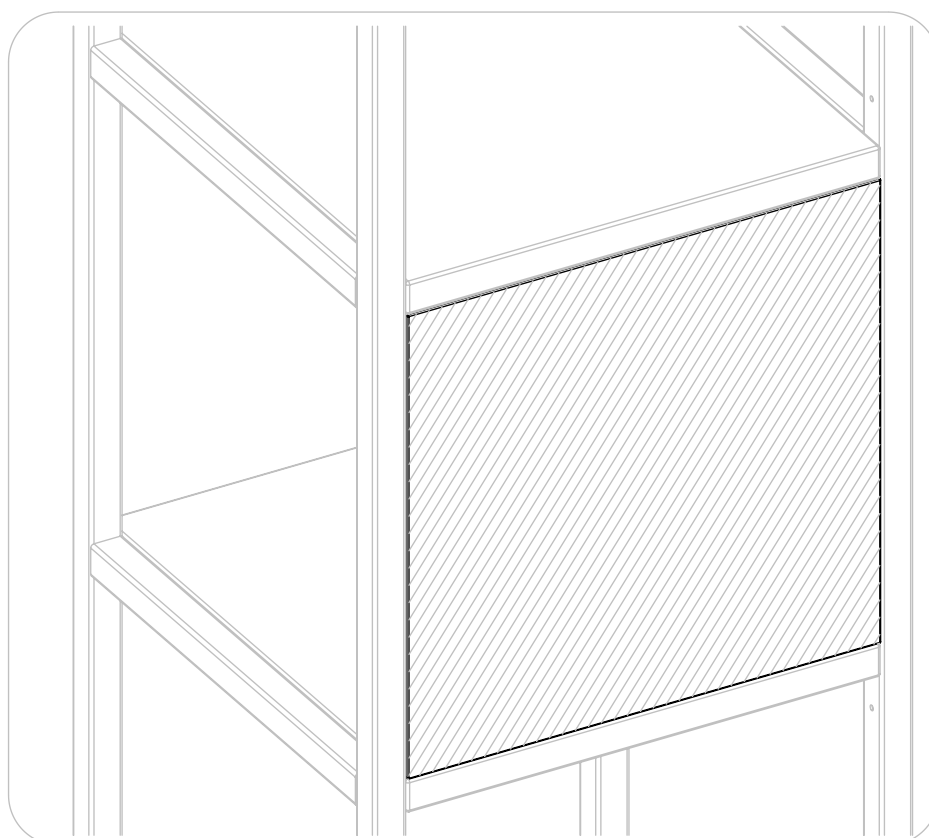

Example of the combination. Specific combination (wide, height, storage components type) depends on order option and chosen components.



Beispiel für eine Kombination. Die konkrete Kombination (Breite, Höhe, Art der Ablagen) hängt von der Wahl der Komponenten und den Bestelloptionen ab.

Exemple de combinaison. La combinaison spécifique (largeur, hauteur, type d'éléments de rangement) dépend de l'option de commande et des éléments choisis.

**i**

Set of storage components depends on order option and chosen accessories. Instructions for other options provided with other packages.  
Das Set der Ablagen hängt von den Bestelloptionen und dem gewählten Zubehör ab. Die Anleitungen für andere Optionen liegen den jeweiligen Packungen bei.  
Le jeu d'éléments de rangement dépend de l'option de commande et des accessoires choisis. Les instructions pour les autres options sont fournies dans leur emballage.

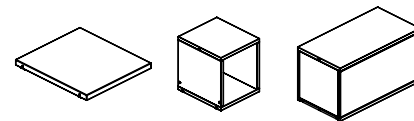
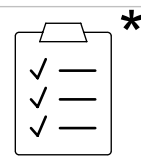

**Units size**

Größe der Einheit

Taille de l'unité

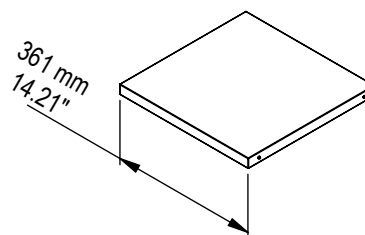
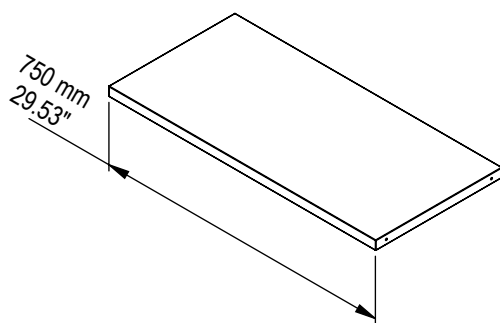

**a**

Melamine back panels

Melamin Rückwände

Mélamine panneaux arrière

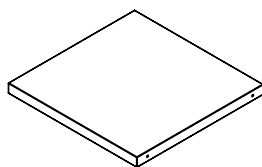
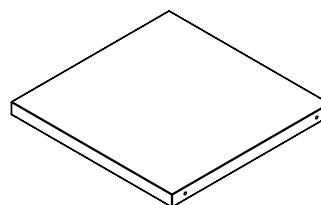

a - x1



M4200111

**b**

PET felt back panels

PET-Filz Rückwände

Feutre PET panneaux arrière

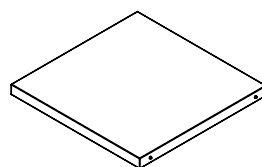
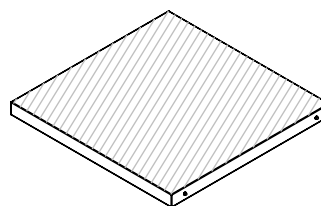

a - x1



# 1a

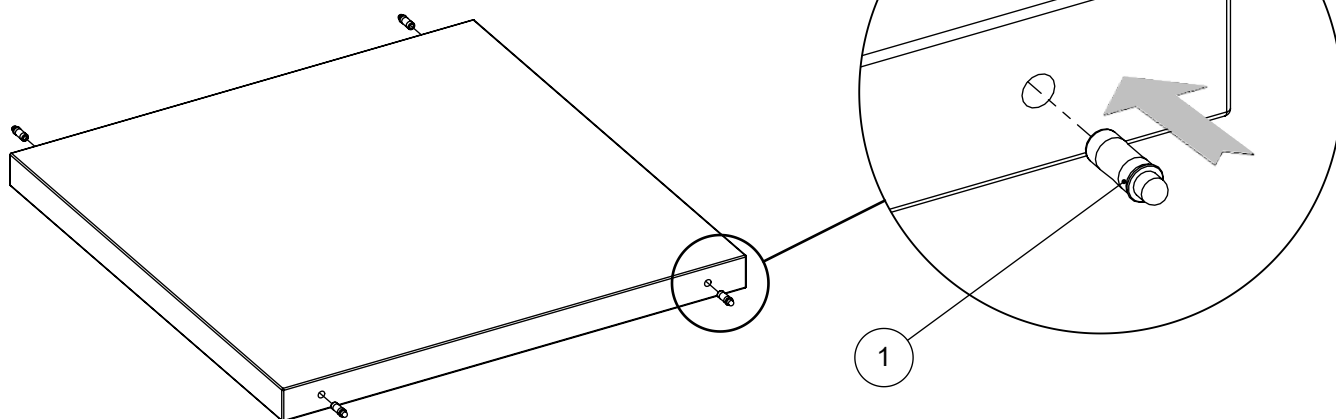
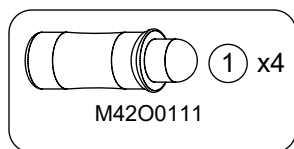

# 2

- 1** Check if the pins are fixed in the position correctly.  
Prüfen, ob die Pins korrekt in ihrer Position fixiert sind.  
Veuillez vérifier si les broches sont correctement fixées à leur place.

